

Saturn 1
 Block 2
 Dimensions in inches
 Drawn by Peter Alway

Sources:
 NASA Drawing 68MSG-0046
 NASA TM X-57401, Saturn 1 Summary
 NASA TN D-2002
 NARTS Saturn 1B scale data packet

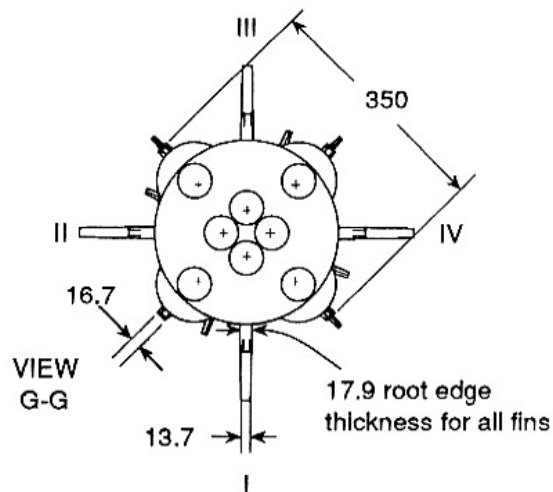

Saturn 1
 Block 2
 Upper stage and spacecraft
 details
 Drawn by Peter Alway

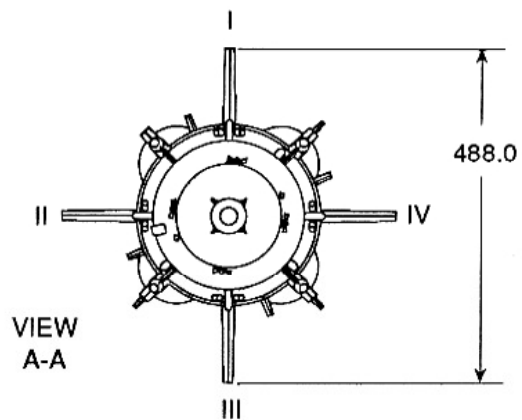
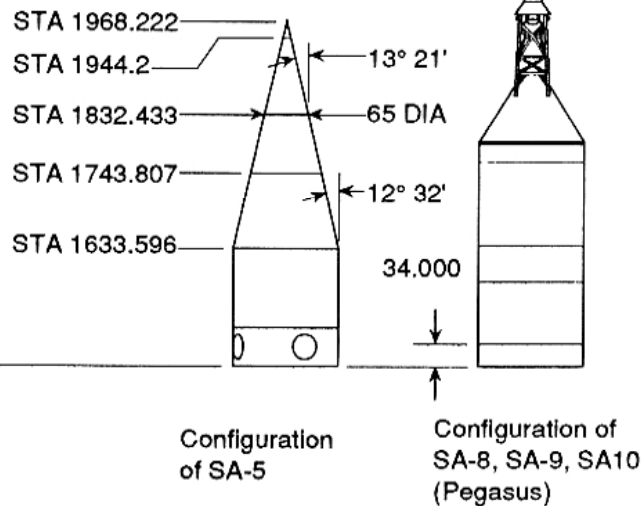
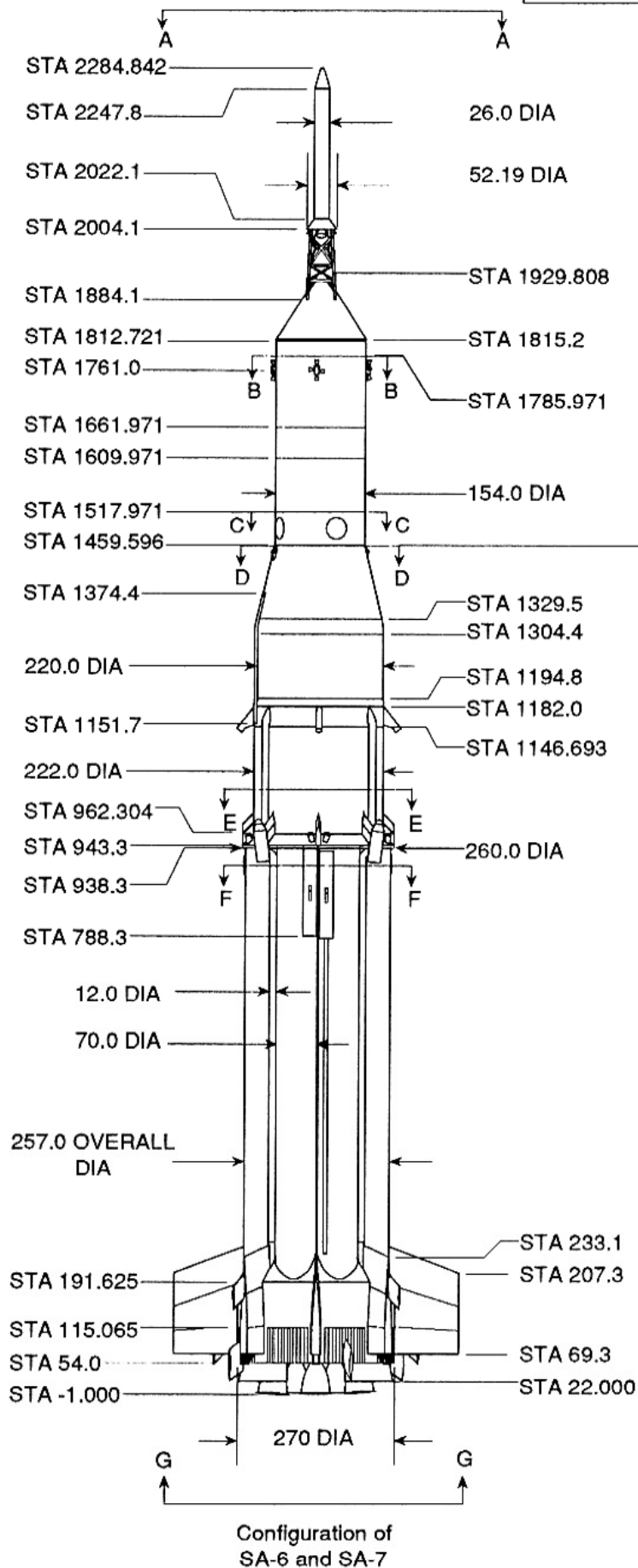
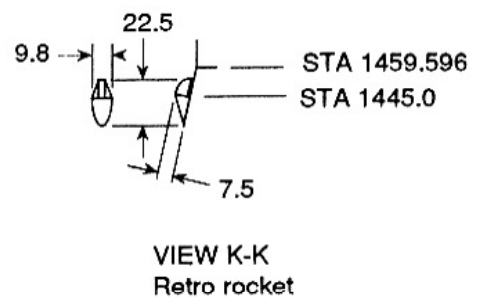
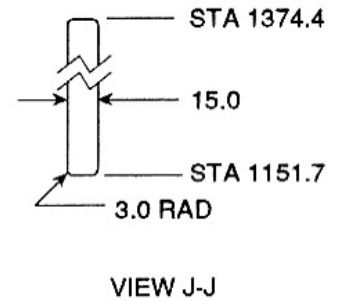
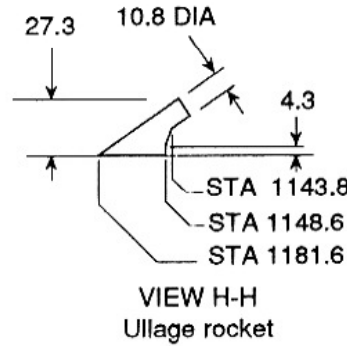
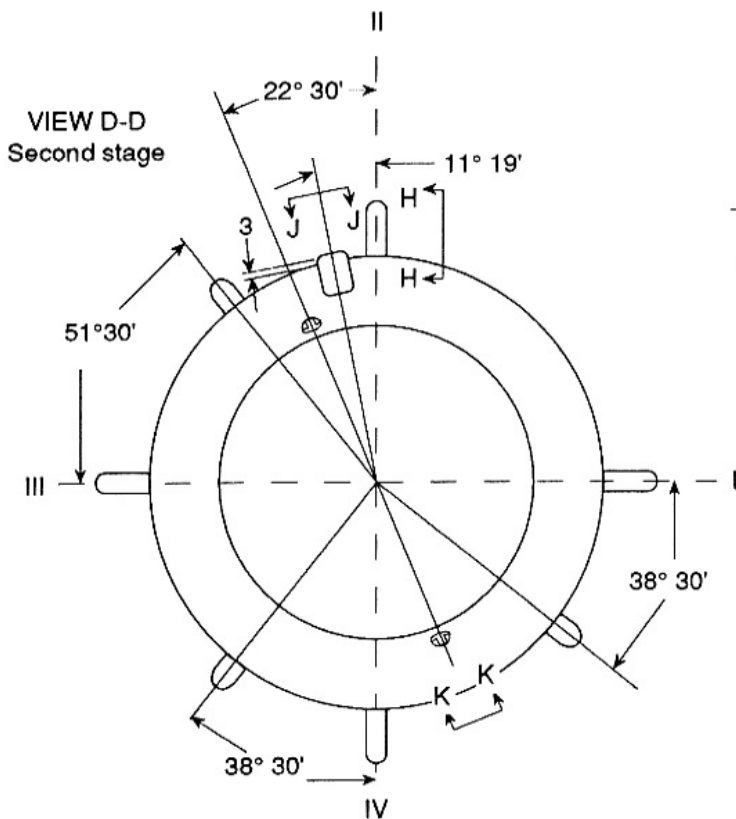
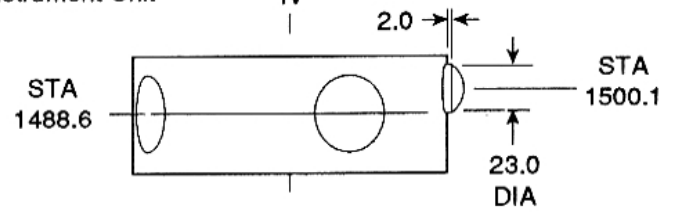
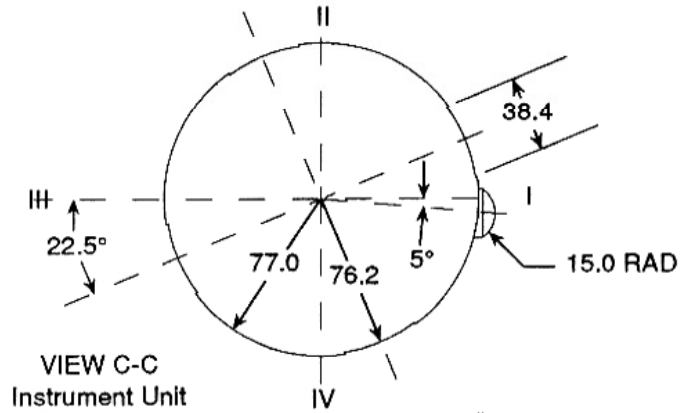
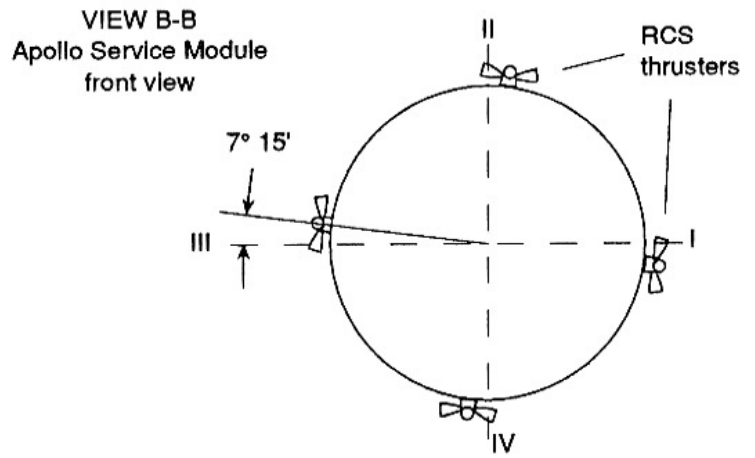
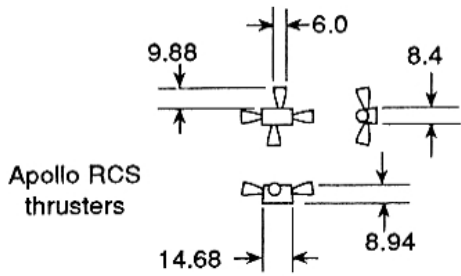
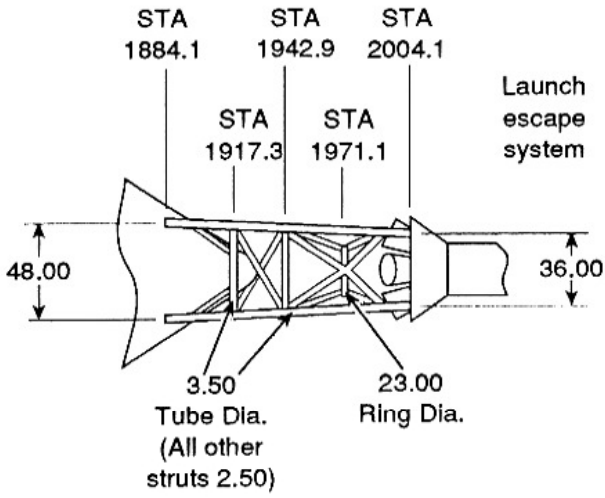

VIEW E-E
 II Top of first stage

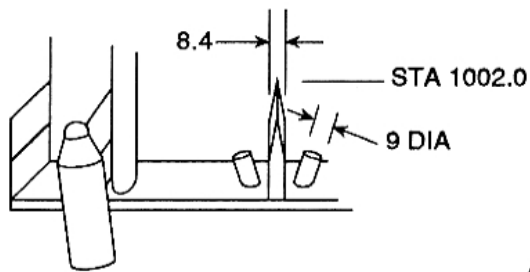
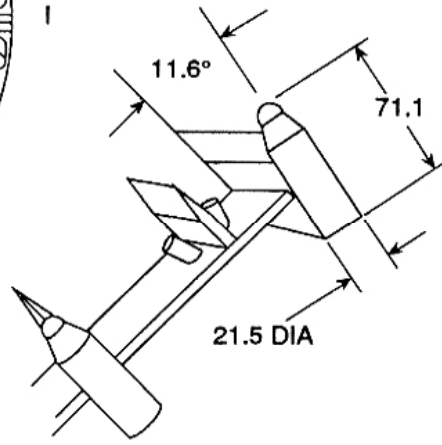
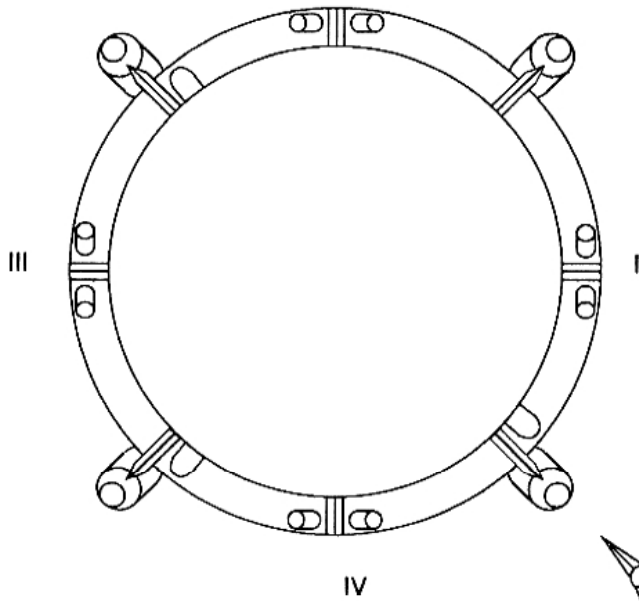

Antenna panels

VIEW F-F
 First stage tanks

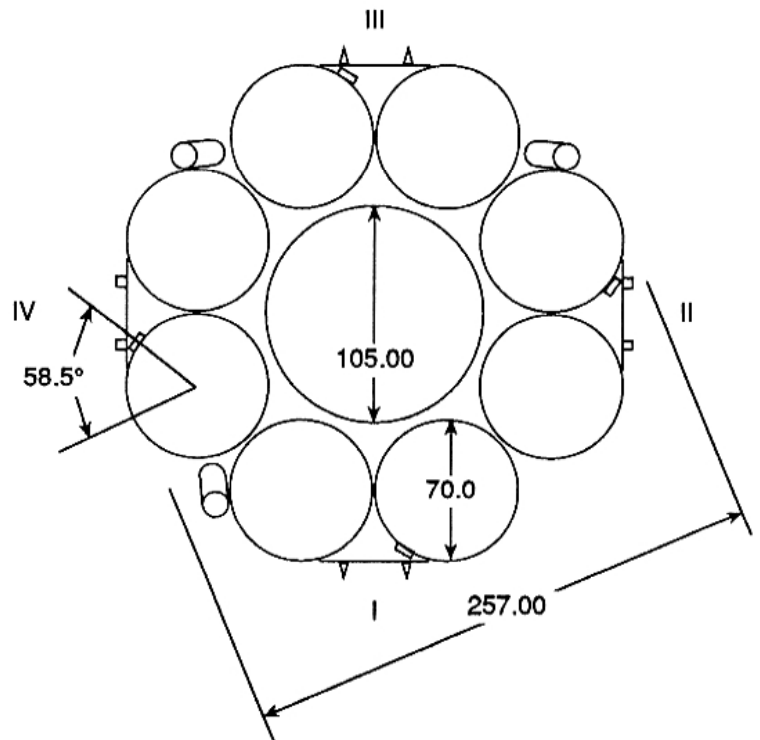

Antenna panels
 Positions I and III

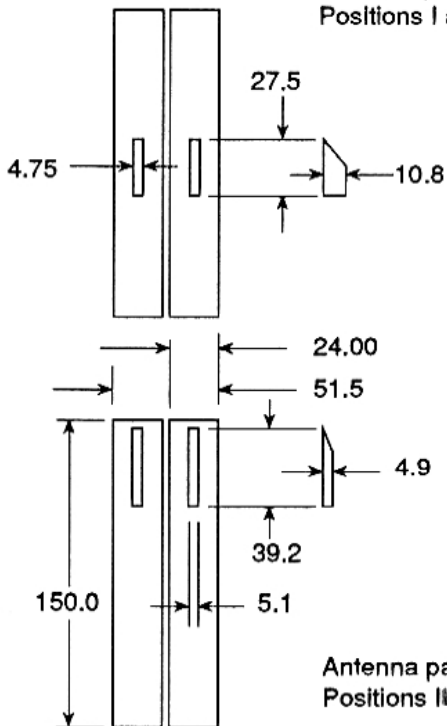

Antenna panels
 Positions II and III

Saturn 1
 Block 2
 Tail section details
 Drawn by Peter Alway

VIEW L-L
 Turbine exhaust

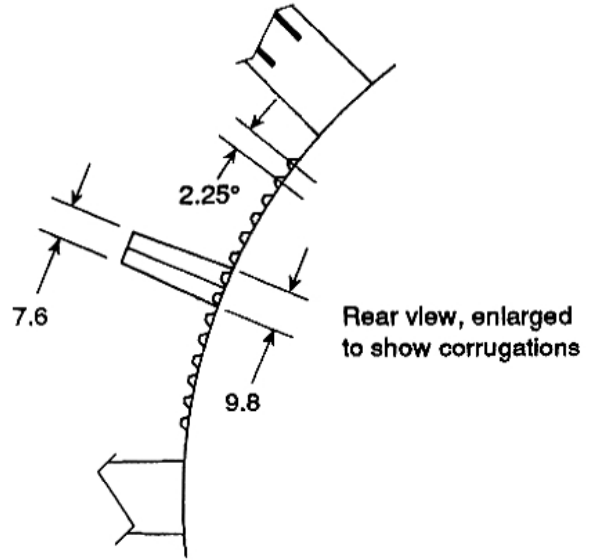
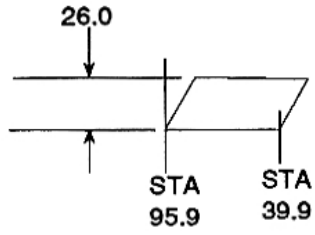

Outboard engines

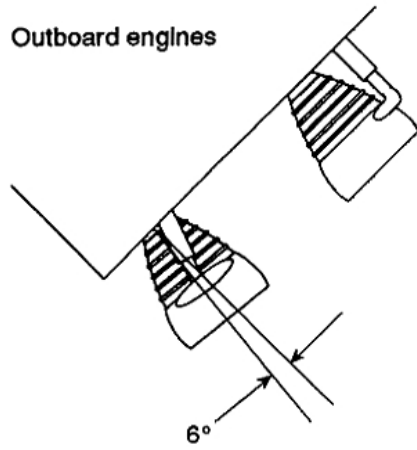

Inboard engine

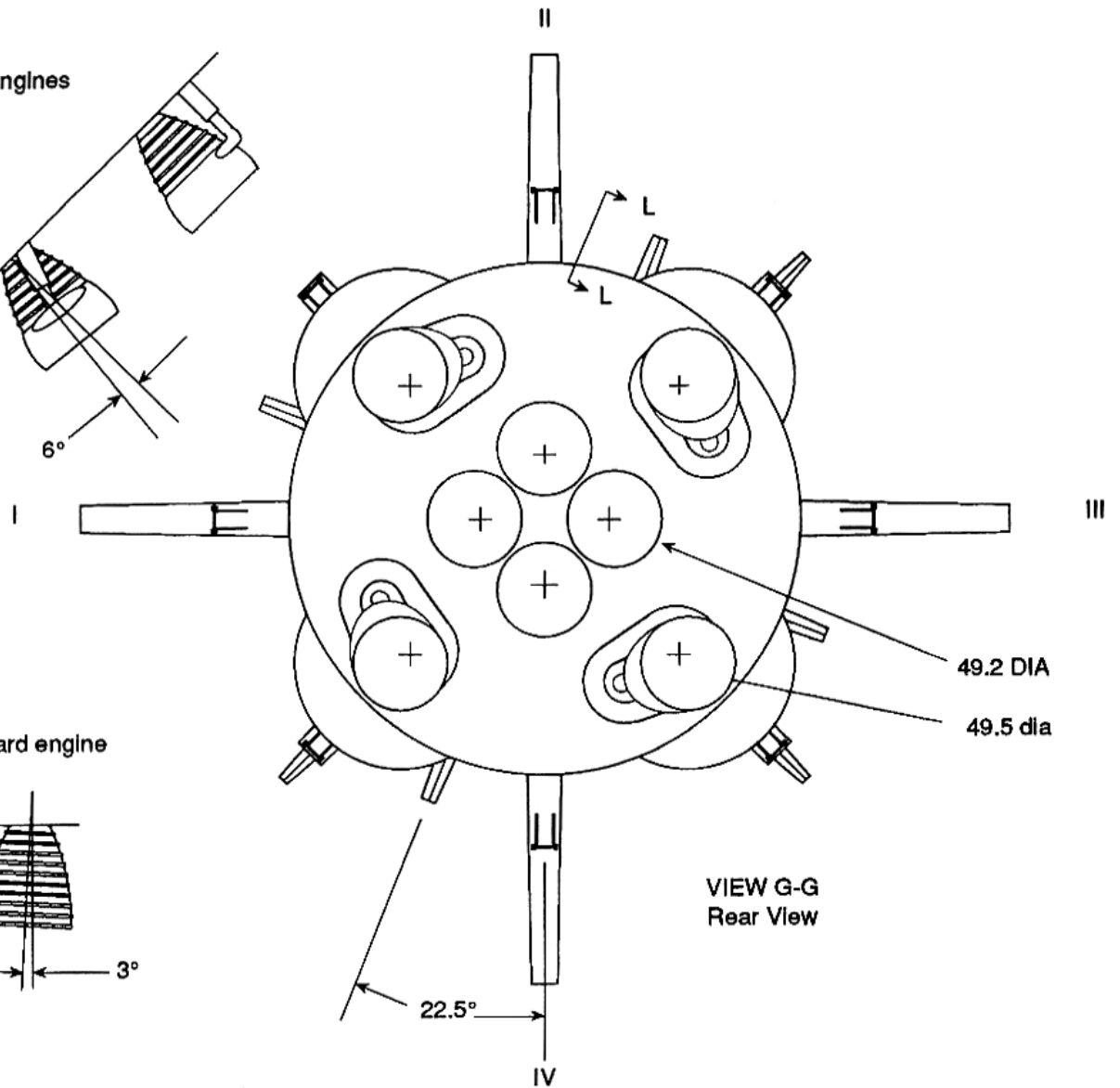
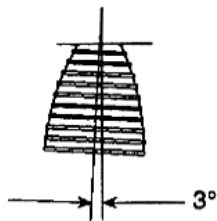

Large fin

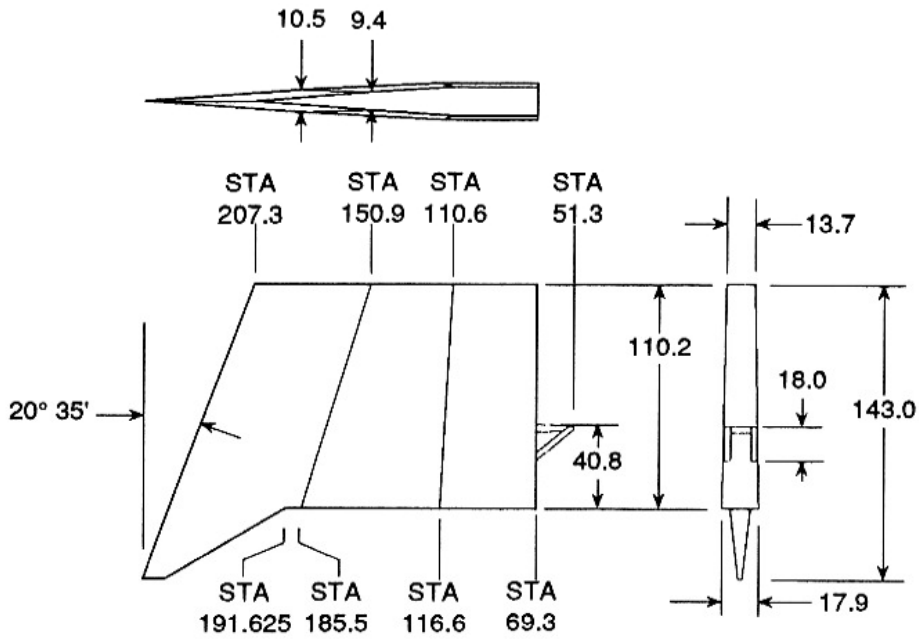

Stub Fin

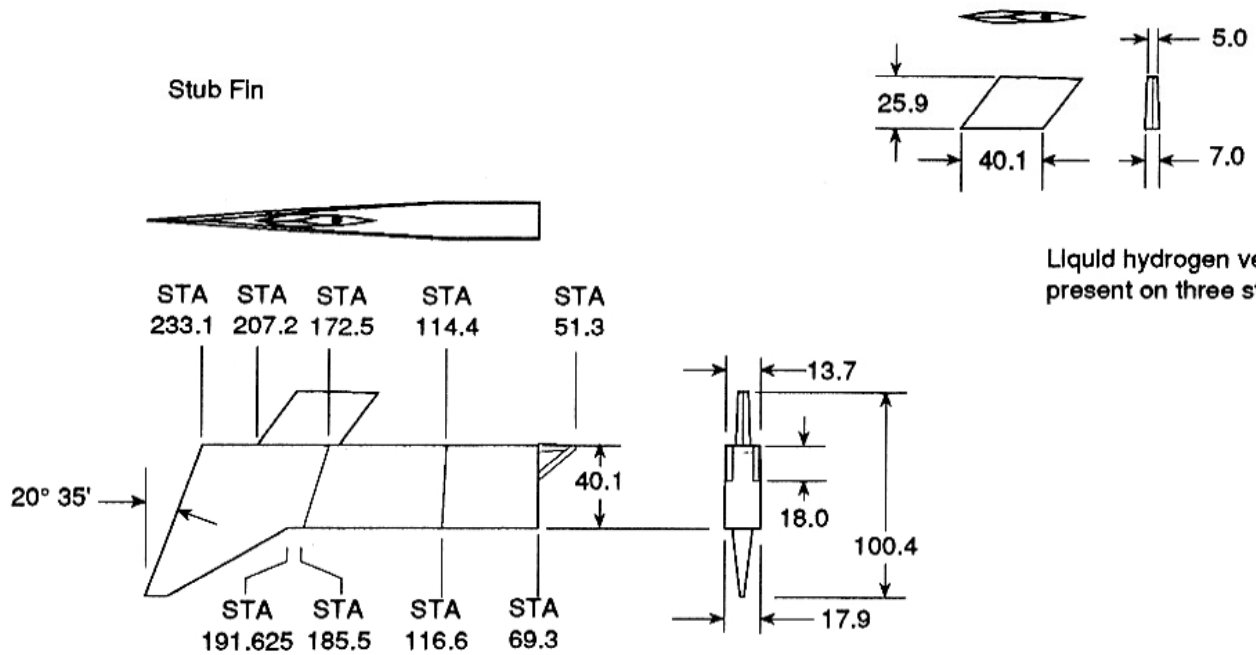

Liquid hydrogen vent
 present on three stub fins