

HI HAT STAND SHOWN WITH AND WITHOUT CYMBALS  
SCALE 1 / 3

DRAWN J. TSCHIRHART	4/21/2011	TITLE	
CHECKED		HI HAT STAND, ASSEMBLY	
QA		SIZE	DWG NO
MFG		C	Hi_Hat_Assembly
APPROVED		SCALE	REV
			SHEET 1 OF 4

PRODUCED BY AN AUTODESK EDUCATIONAL PRODUCT

PRODUCED BY AN AUTODESK EDUCATIONAL PRODUCT

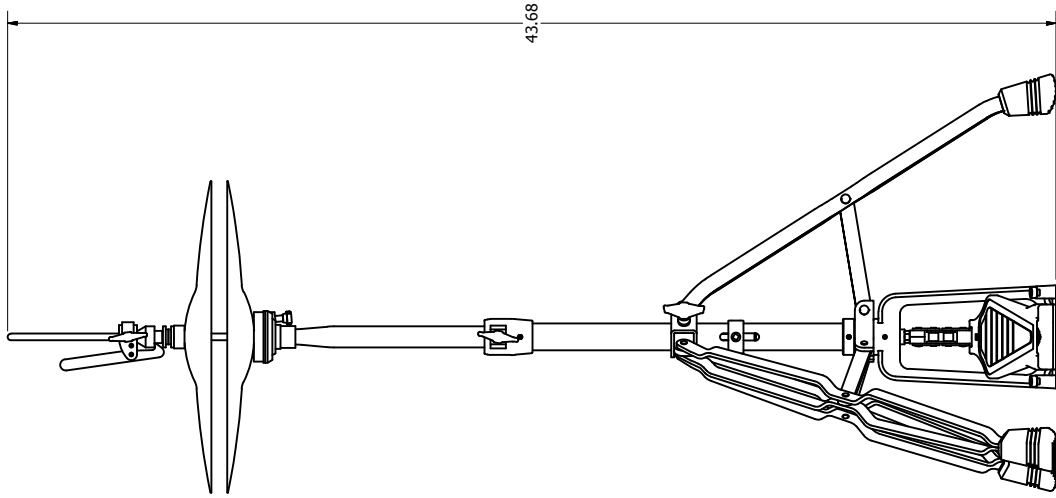

HI HAT STAND, DEFAULT POSITION  
SCALE 1 / 4

(SOME COMPONENT AND/OR SUBASSEMBLY  
POSITIONS MAY VARY PER USER)

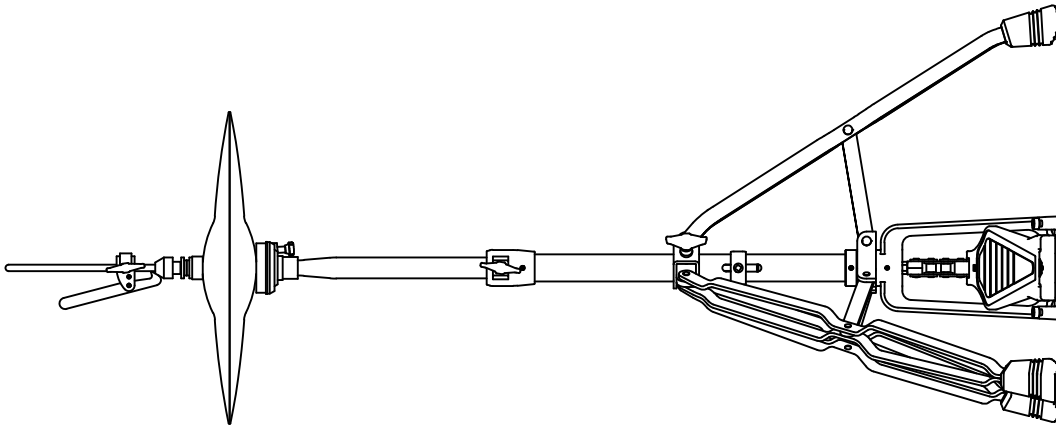

SHOWN WITH DROP CLUTCH IN USE

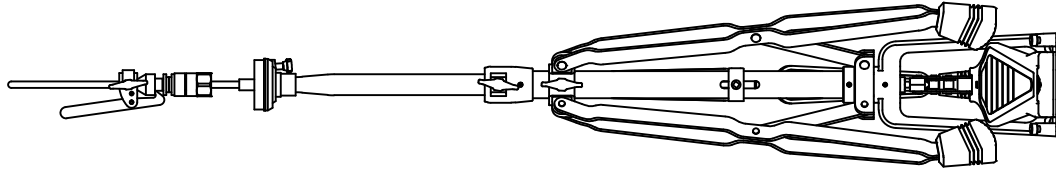

SHOWN WITH LEGS RETRACTED FOR TRANSPORT

DRAWN J. TSCHIRHART	4/21/2011	TITLE	
CHECKED			
QA			
MFG			
APPROVED			
		SIZE	DWG NO
		C	Hi_Hat_Assembly
		SCALE	REV
			1

HI HAT STAND, ASSEMBLY

PRODUCED BY AN AUTODESK EDUCATIONAL PRODUCT

PRODUCED BY AN AUTODESK EDUCATIONAL PRODUCT

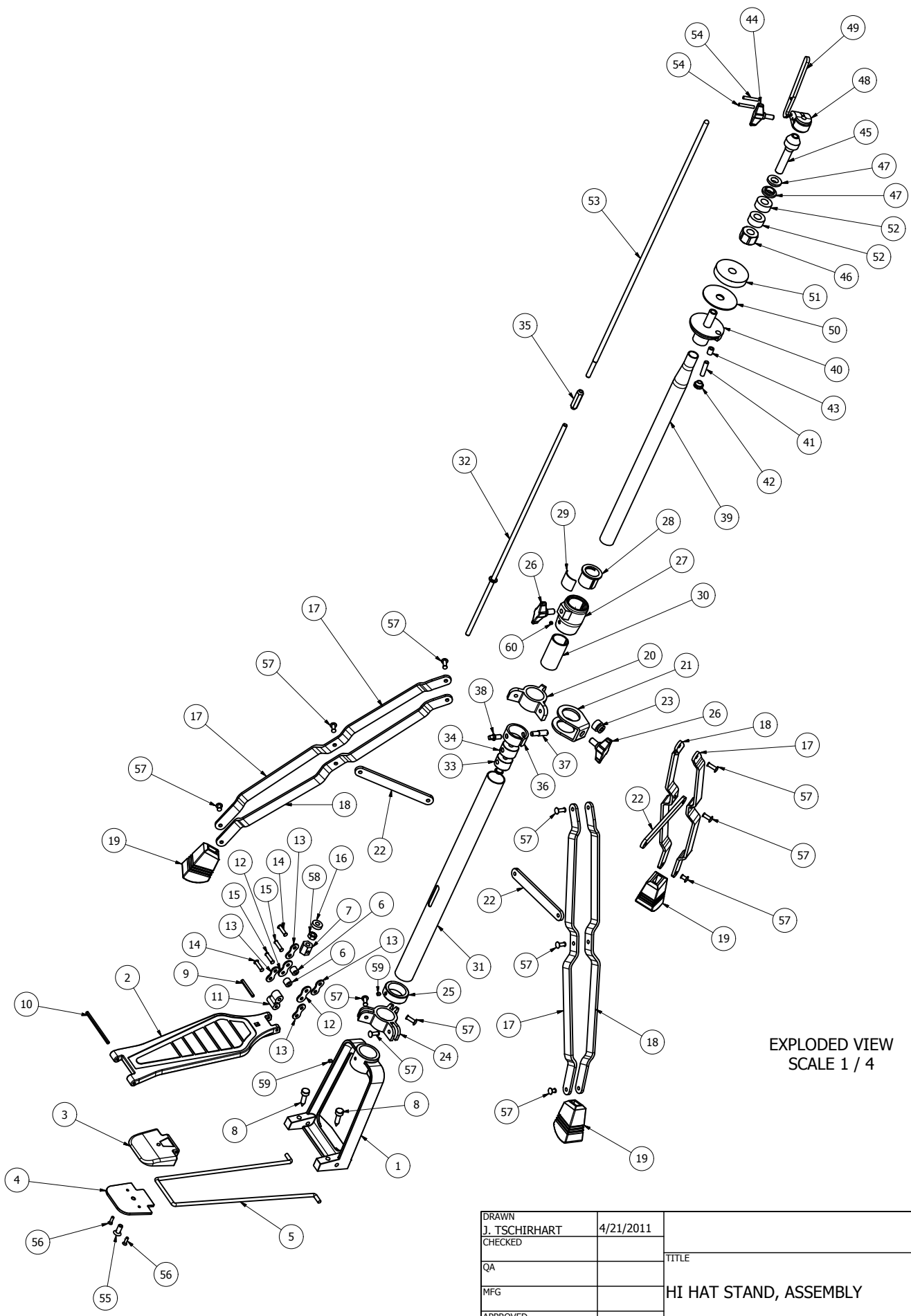

EXPLODED VIEW  
SCALE 1 / 4

DRAWN J. TSCHIRHART		4/21/2011		TITLE	
CHECKED				HI HAT STAND, ASSEMBLY	
QA				SIZE	
MFG				C	
APPROVED				DWG NO	
				Hi_Hat_Assembly	
				REV	
				SCALE	
				SHEET 3 OF 4	

PARTS LIST	
ITEM	DESCRIPTION
1	PEDAL FRAME, (CAST)
2	PEDAL BODY
3	HEEL PLATE, TOP
4	HEEL PLATE, BASE
5	PEDAL JOINING ROD
6	STANDOFF, CHAIN
7	ROD ATTACHMENT, BASE
8	ANCHOR SPIKE
9	SPRING PIN, TOE
10	SPRING PIN, HEEL
11	PEDAL LINK
12	CHAIN LINK, LARGE
13	CHAIN LINK, SMALL
14	CHAIN PIN 1
15	CHAIN PIN 2
16	FELT, ROD STOPPER
17	LEG HALF A
18	LEG HALF B
19	FOOT
20	LEG ATTACHMENT, UPPER
21	LEG ATTACHMENT, BRACE
22	LEG STRUT
23	LEG ATTACHMENT THREADED RIVET
24	LEG ATTACHMENT, LOWER
25	LOCK RING
26	COUPLING & LEG WINGNUT
27	COUPLING
28	COUPLING INSERT
29	PRESSURE PLATE
30	CORE INSERT
31	CORE TUBE
32	CENTER ROD (LOWER HALF)
33	TENSION CORE
34	TENSION SHELL
35	ROD COUPLER
36	TENSION OUTER RING
37	TENSION SLOTTED LUG
38	TENSION LUG
39	UPPER TUBE
40	CYMBAL SEAT
41	TILTER
42	TILTER KNOB
43	TILTER INSERT
44	CLUTCH WINGNUT
45	MAIN CLUTCH BODY
46	CLUTCH NUT
47	THUMB NUT
48	DROP CLUTCH BODY
49	DROP CLUTCH LEVER
50	FENDER WASHER
51	FELT (LARGE)
52	FELT (SMALL)
53	CENTER ROD (UPPER)
54	SPRING PIN, DROP CLUTCH
55	1/4-20 FLAT HD SCREW 5/8" LONG
56	6-32 FLAT HD SCREW 1/2" LONG
57	TRUSS HD RIVET .19" DIA.
58	1/4-20 UNC HEX NUT
59	8-36 UNF SOC. HD. SET SCREW 3/16" LONG
60	8-36 UNF SOC. HD. SET SCREW 1/8" LONG

DRAWN	J. TSCHIRHART	4/21/2011	TITLE
CHECKED			HI HAT STAND, ASSEMBLY
QA			
MFG			
APPROVED			
SIZE	C	SCALE	
DWG NO	Hi_Hat_Assembly	REV	

D

I

C

4

B

I

A

1

2

3

4

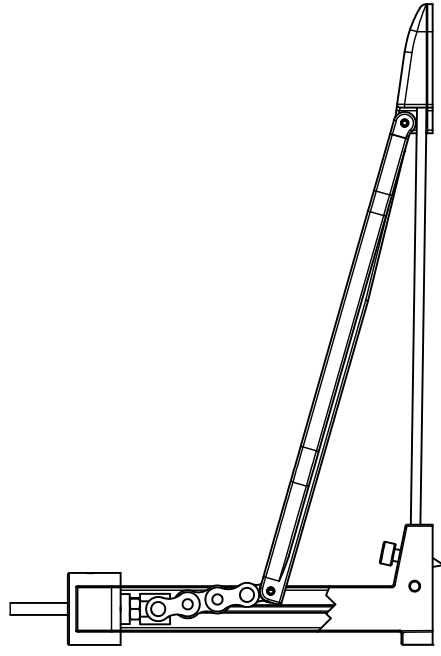
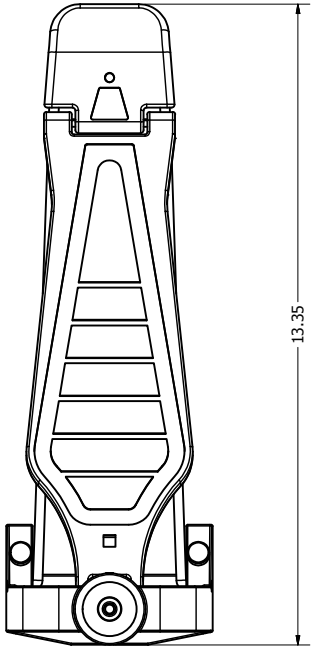
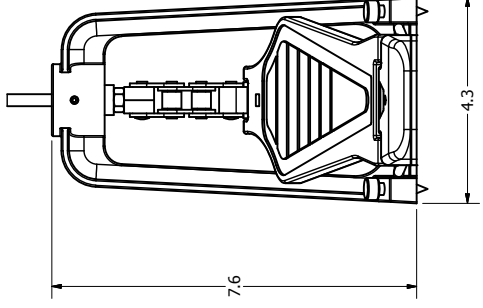
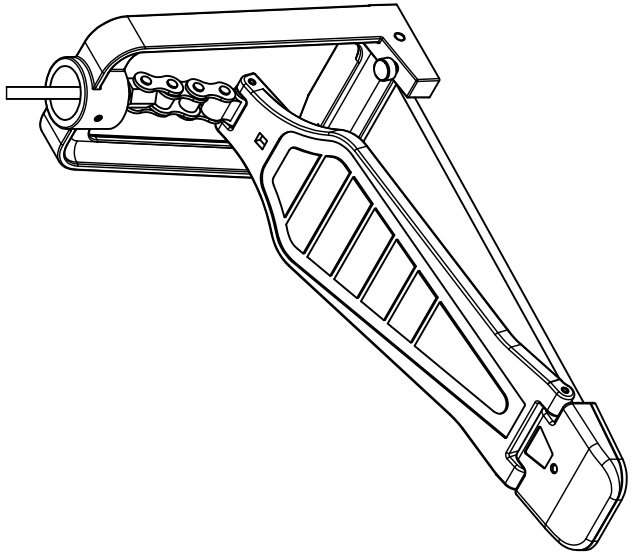

PEDAL ASSEMBLY  
 SCALE 1 / 2  
 (SHOWN WITH CENTER ROD ATTACHED)

DRAWN J. TSCHIRHART	4/29/2011	TITLE	
CHECKED			
QA			
MFG			
APPROVED			
		PEDAL ASSEMBLY	
		SIZE	DWG NO
		C	Pedal_Assembly
		SCALE	REV

D

I

C

4

B

I

A

4

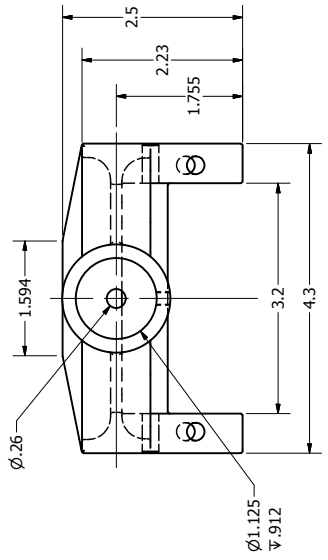

FILLETS AND ROUNDS R.031 UNLESS OTHERWISE NOTED

OBJECT IS SYMMETRICAL

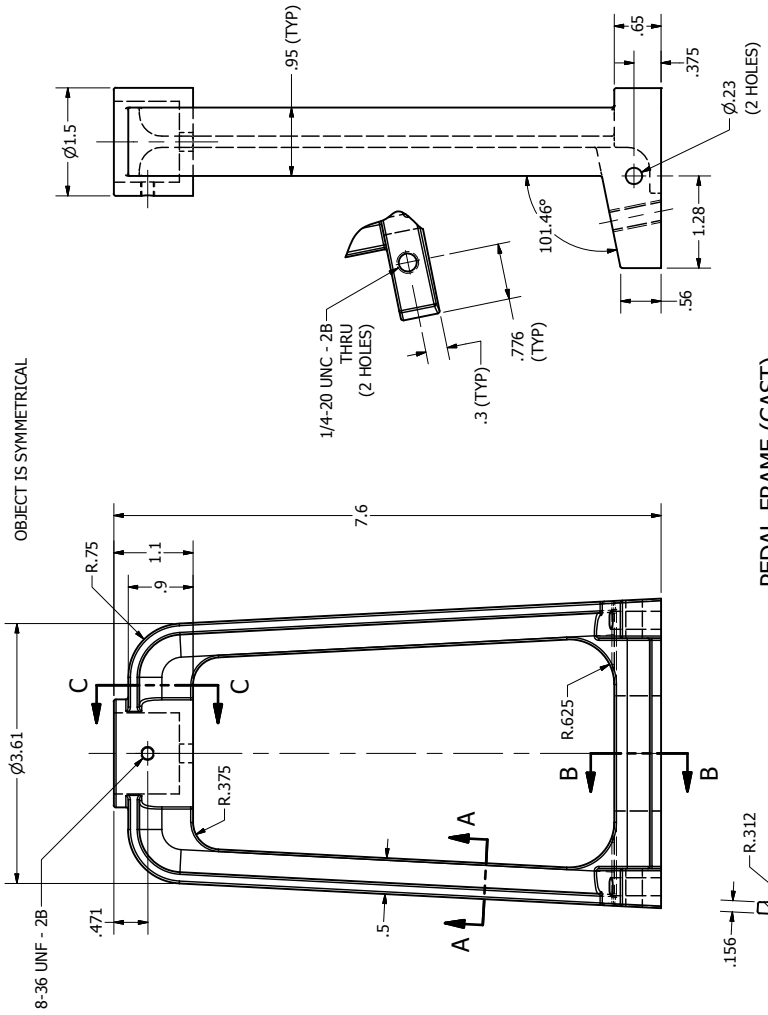

PEDAL FRAME (CAST)  
SCALE .75/1

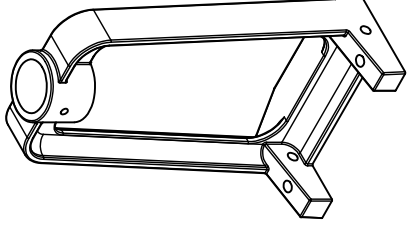

ISOMETRIC VIEWS  
SCALE 1 / 2

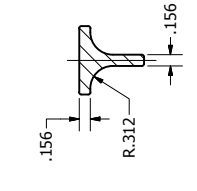

SECTION C-C

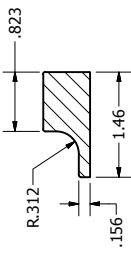

SECTION B-B

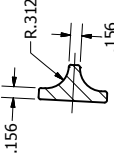

SECTION A-A

DRAWN J. TSCHIRHART	4/29/2011	TITLE	PEDAL ASSEMBLY		
CHECKED QA			SIZE C	DWG NO Pedal_Assembly	REV
			SCALE		SHEET 2 OF 5

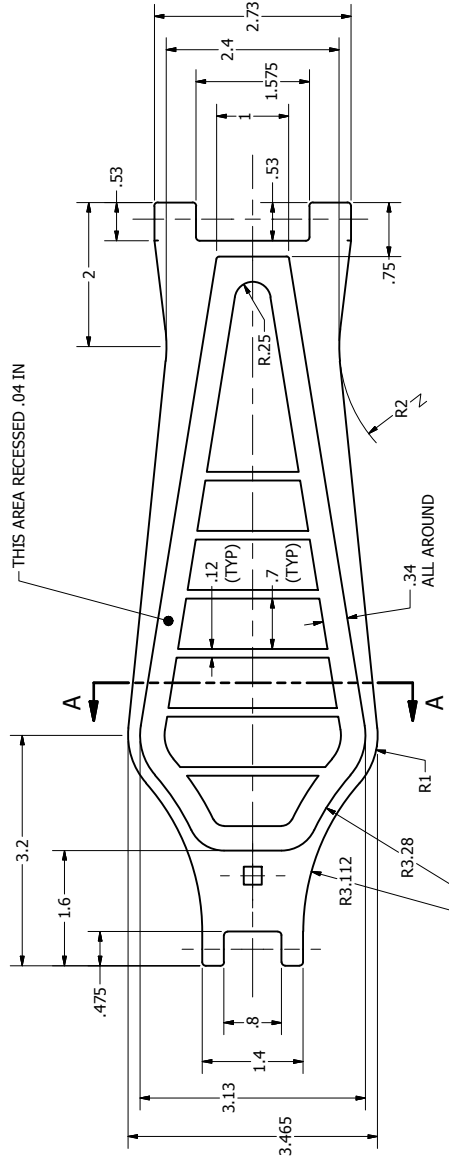

SECTION A-A

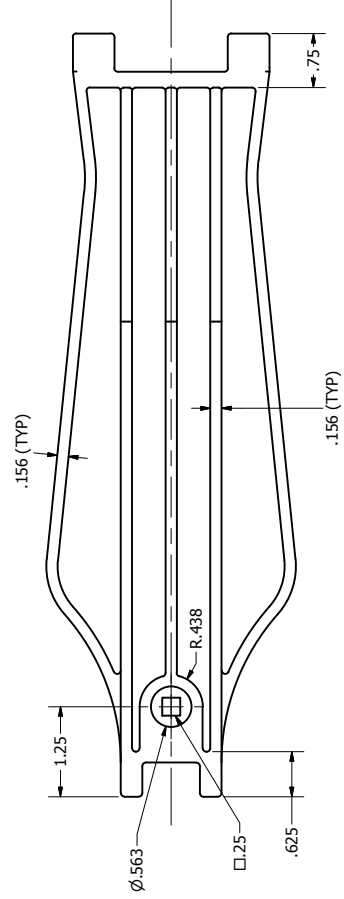
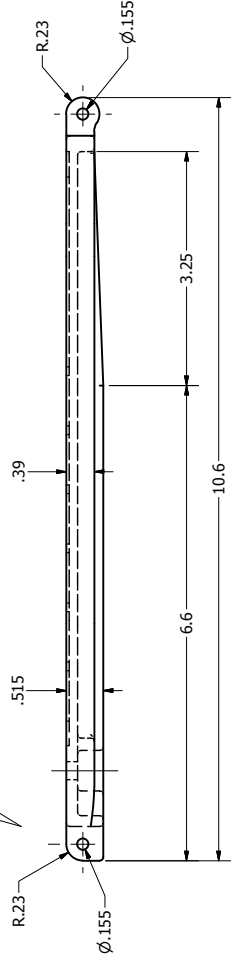
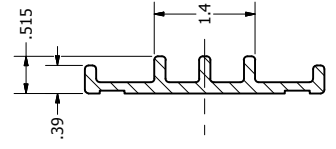

ROUNDS AND FILLETS R.05 UNLESS OTHERWISE SPECIFIED  
OBJECT IS SYMMETRICAL

PEDAL BODY  
SCALE .75/1

DRAWN J. TSCHIRHART	4/29/2011	TITLE
CHECKED		
QA		
MFG		
APPROVED		
		PEDAL ASSEMBLY
SIZE C	DWG NO Pedal_Assembly	REV
SCALE		

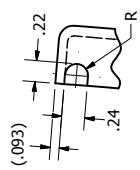
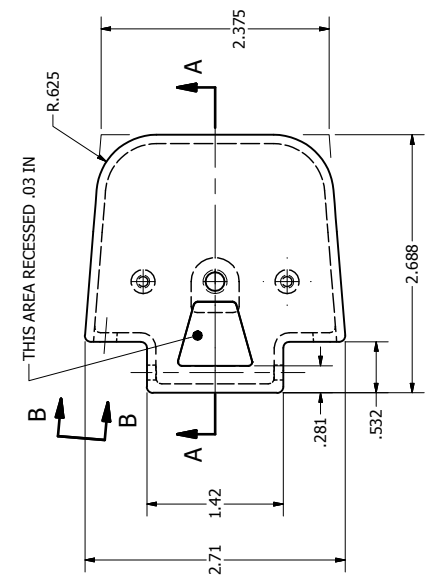

PART WALL THICKNESS .093  
 OBJECT IS SYMMETRICAL  
 FILLETS AND ROUNDS R.063  
 UNLESS OTHERWISE SPECIFIED

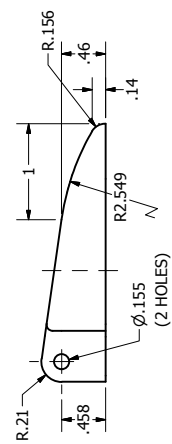
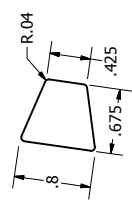

HEEL PLATE TOP  
 SCALE 1 : 1

SECTION A-A

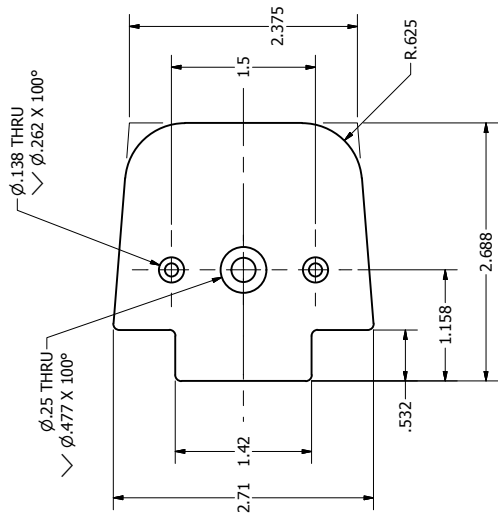
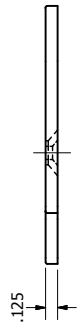

HEEL PLATE BASE  
 SCALE 1 : 1

OBJECT IS SYMMETRICAL  
 FILLETS AND ROUNDS R.063  
 UNLESS OTHERWISE SPECIFIED

DRAWN J. TSCHIRHART	4/29/2011	TITLE	PEDAL ASSEMBLY	
CHECKED			SIZE	DWG NO
QA			C	Pedal_Assembly
MFG			SCALE	
APPROVED				REV
				1



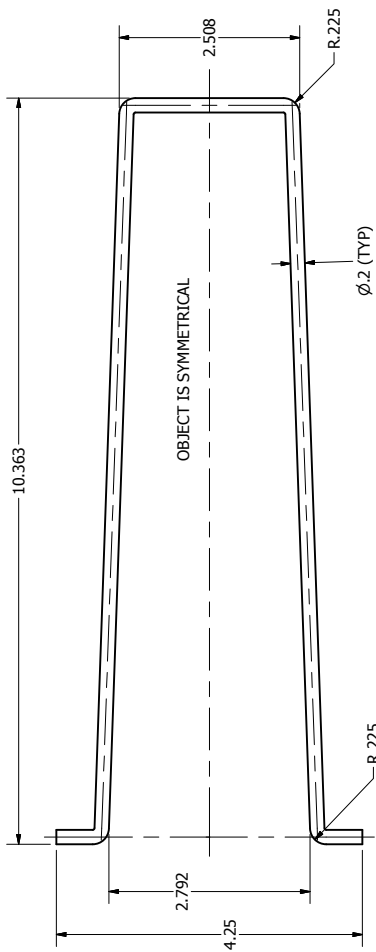

PEDAL JOINING ROD  
SCALE .75/1

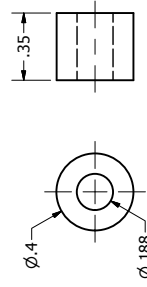

CHAIN STANDOFF  
SCALE 2 : 1

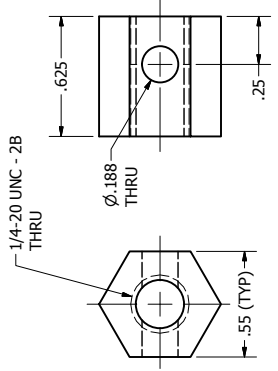

ROD ATTACH NUT  
SCALE 2 : 1

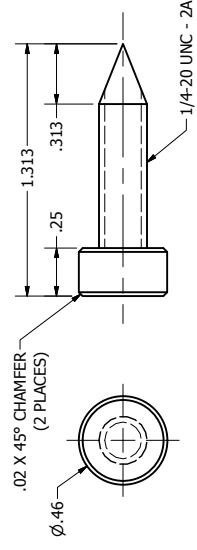

ANCHOR SPIKE  
SCALE 2 : 1

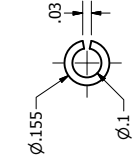

SPRING PIN, TOE  
SCALE 3 : 1

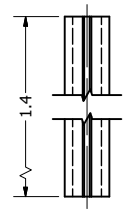

SPRING PIN, HEEL  
SCALE 3 : 1

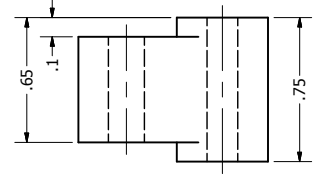

PEDAL LINK  
SCALE 2 : 1

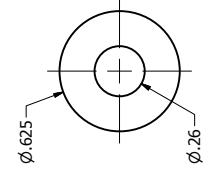

FELT STOPPER  
SCALE 2 : 1

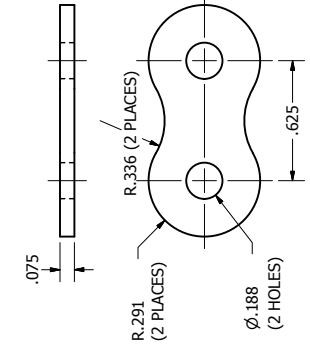

CHAIN LINK, LARGE  
SCALE 2 : 1

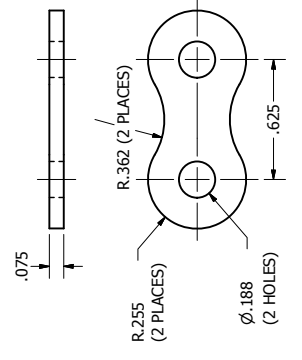

CHAIN LINK, SMALL  
SCALE 2 : 1

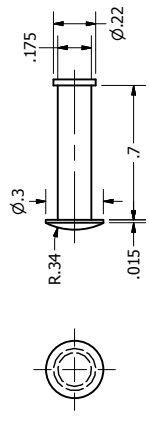

CHAIN PIN 1  
SCALE 2 : 1

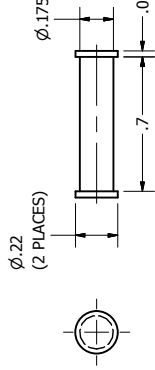

CHAIN PIN 2  
SCALE 2 : 1

DRAWN J. TSCHIRHART	4/29/2011	TITLE
CHECKED QA		PEDAL ASSEMBLY
MFG APPROVED		
SIZE C	SCALE	REV
		Pedal_Assembly
		SHEET 5 OF 5

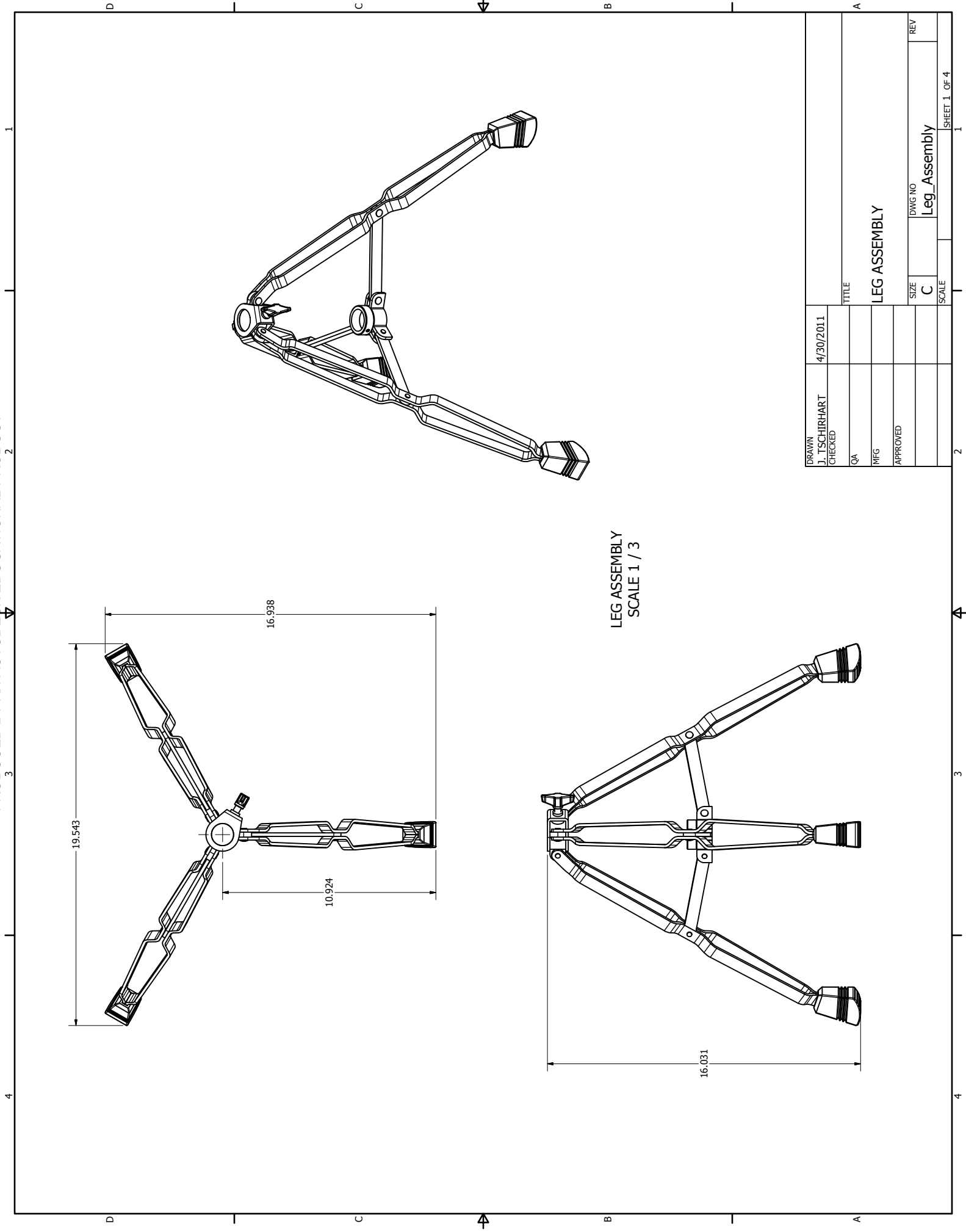

LEG ASSEMBLY  
SCALE 1 / 3

DRAWN J. TSCHIRHART	4/30/2011	TITLE	LEG ASSEMBLY
CHECKED		SIZE	C
QA		DWG NO	Leg_Assembly
MFG		SCALE	
APPROVED		REV	
			SHEET 1 OF 4

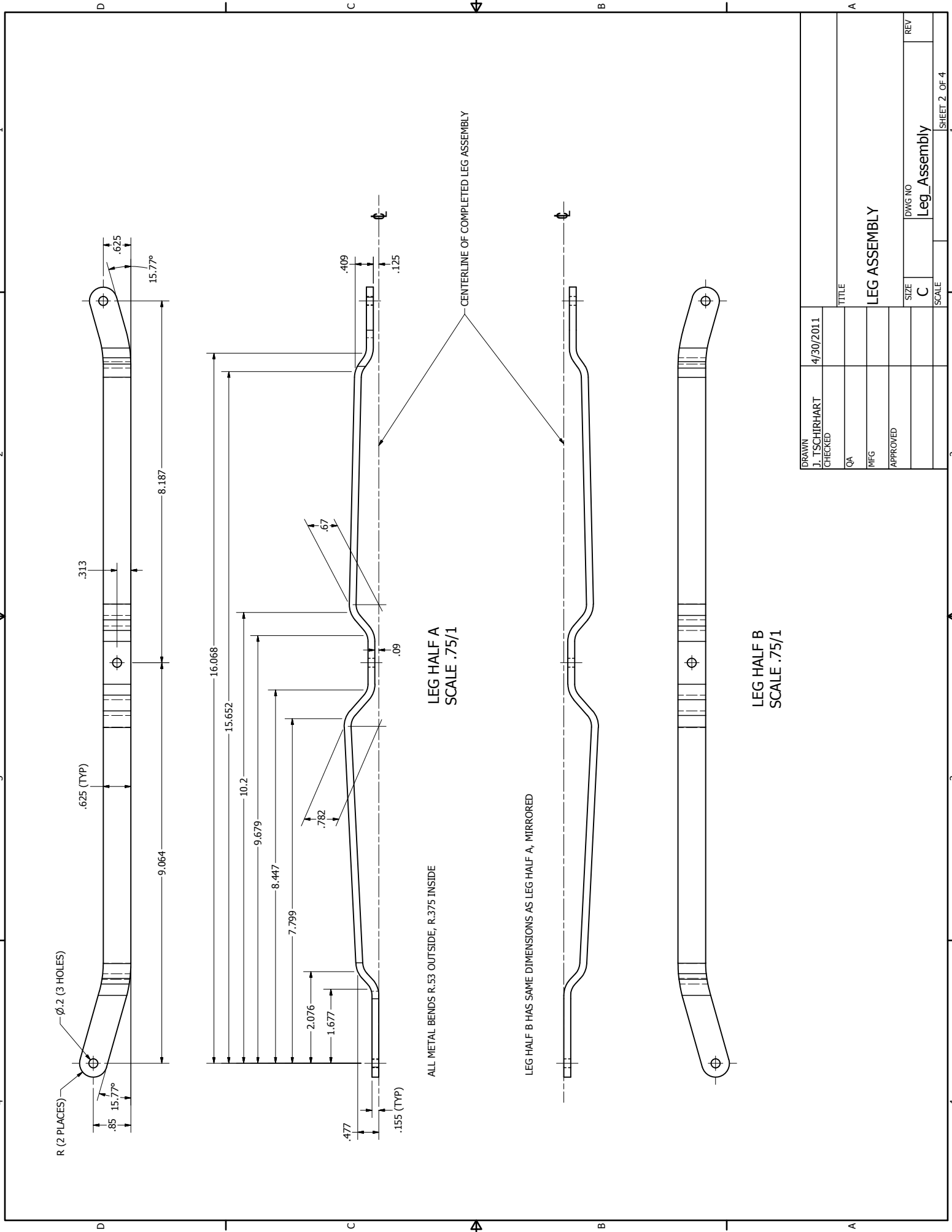

R (2 PLACES)

Ø.2 (3 HOLES)

.85  
15.77°

.625 (TYP)

3.13

.625  
15.77°

8.187

9.064

16.068

15.652

10.2

9.679

8.447

7.799

2.076

1.677

.782

.67

.409

.155 (TYP)

.09

.125

ALL METAL BENDS R.53 OUTSIDE, R.375 INSIDE

LEG HALF A  
SCALE .75/1

CENTERLINE OF COMPLETED LEG ASSEMBLY

LEG HALF B HAS SAME DIMENSIONS AS LEG HALF A, MIRRORED

LEG HALF B  
SCALE .75/1

DRAWN J. TSCHIRHART	4/30/2011	TITLE	LEG ASSEMBLY
CHECKED		SIZE	C
QA		DWG NO	Leg_Assembly
MFG		SCALE	
APPROVED		REV	

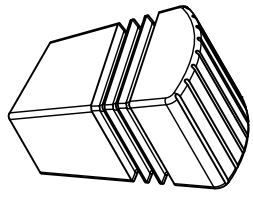
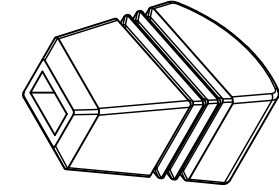
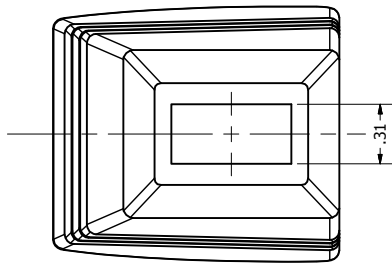

ISOMETRIC VIEWS  
SCALE 1 : 1

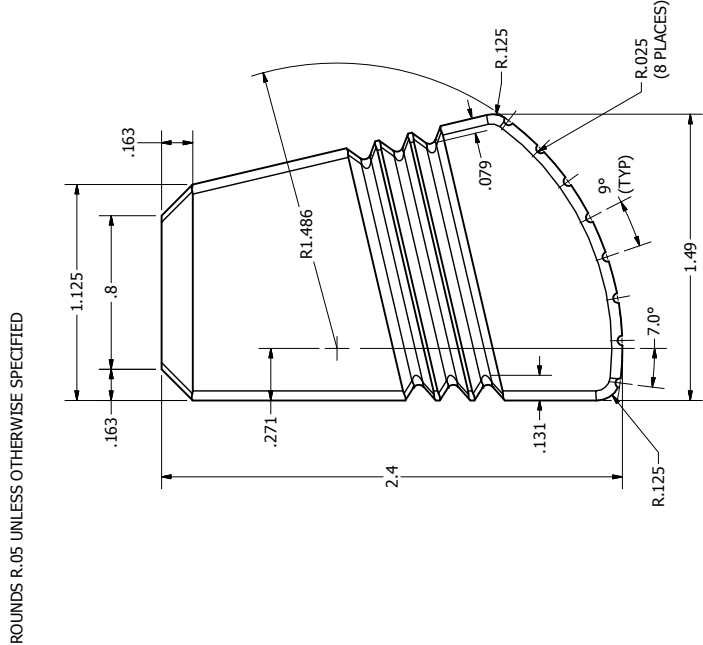
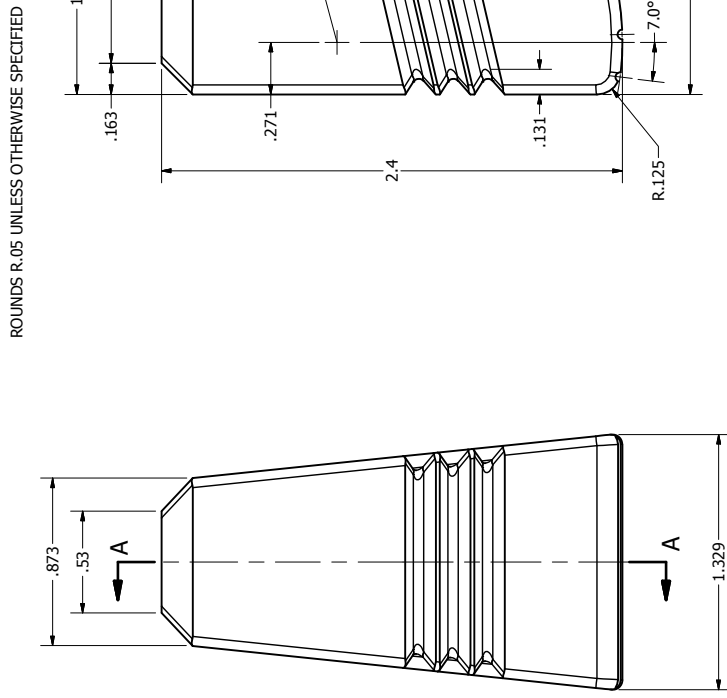

ROUNDS R.05 UNLESS OTHERWISE SPECIFIED

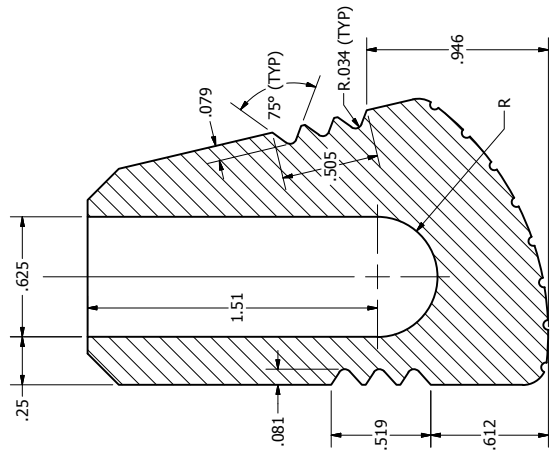

SECTION A-A

FOOT  
SCALE 2 : 1

DRAWN J. TSCHIRHART	4/30/2011	TITLE
CHECKED		LEG ASSEMBLY
QA		
MFG		
APPROVED		
SIZE C	DWG NO Leg_Assembly	REV
SCALE		SHEET 3 OF 4

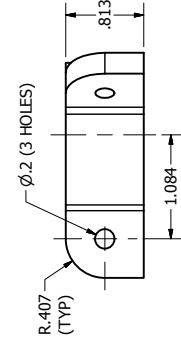
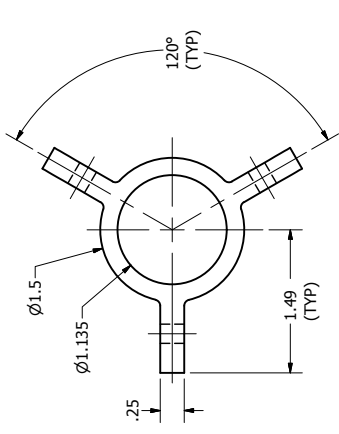

LEG ATTACHMENT, UPPER  
SCALE 1 : 1

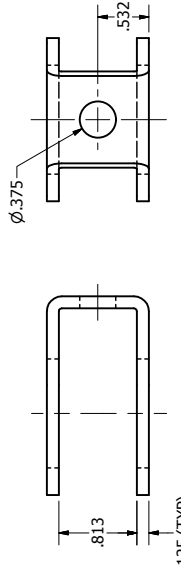
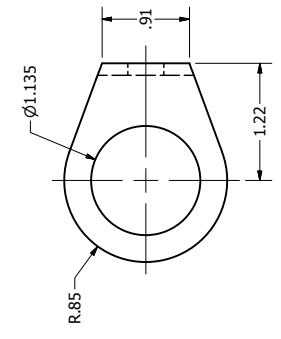

LEG ATTACHMENT BRACE  
SCALE 1 : 1

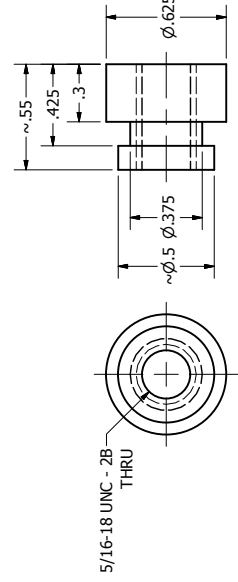

LEG ATTACHMENT THREADED RIVET  
(SHOWN IN FINAL CONFIGURATION)  
SCALE 2 : 1

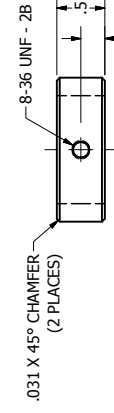
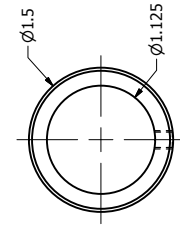

LOCK RING  
SCALE 1 : 1

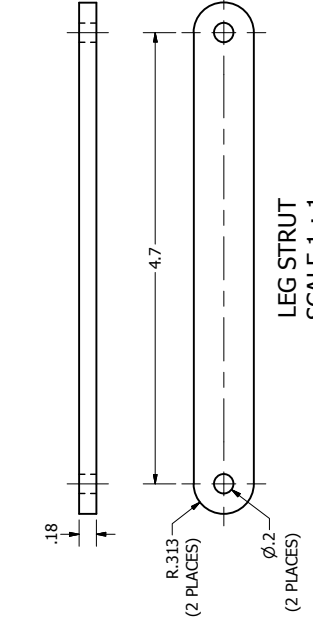

LEG STRUT  
SCALE 1 : 1

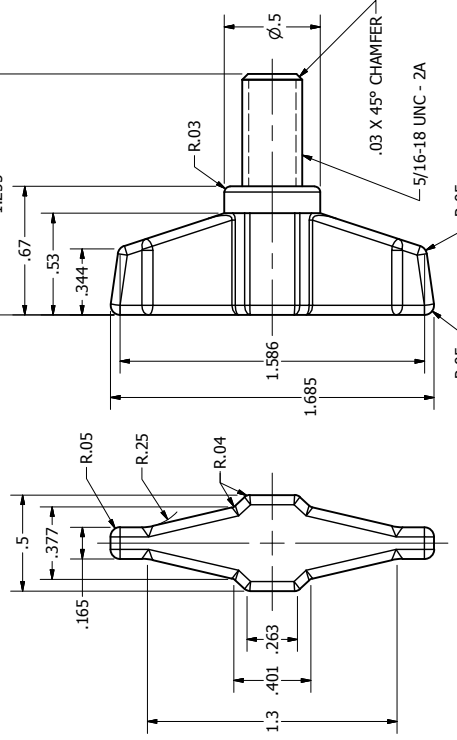

COUPLING & LEG WINGNUT  
SCALE 2 : 1

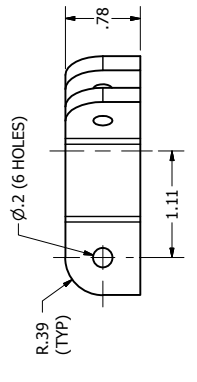
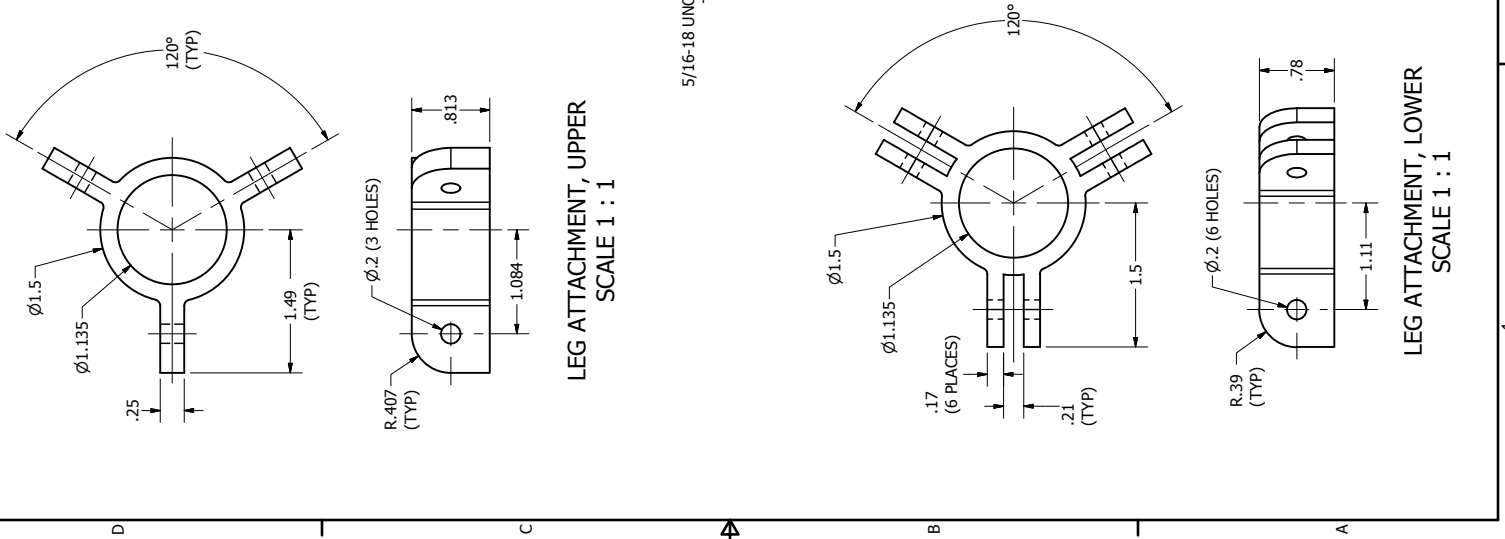

LEG ATTACHMENT, LOWER  
SCALE 1 : 1

DRAWN J. TSCHIRHART	4/30/2011	TITLE
CHECKED		
QA		
MFG		
APPROVED		
LEG ASSEMBLY		REV
SIZE C	DWG NO Leg_Assembly	
SCALE		SHEET 4 OF 4

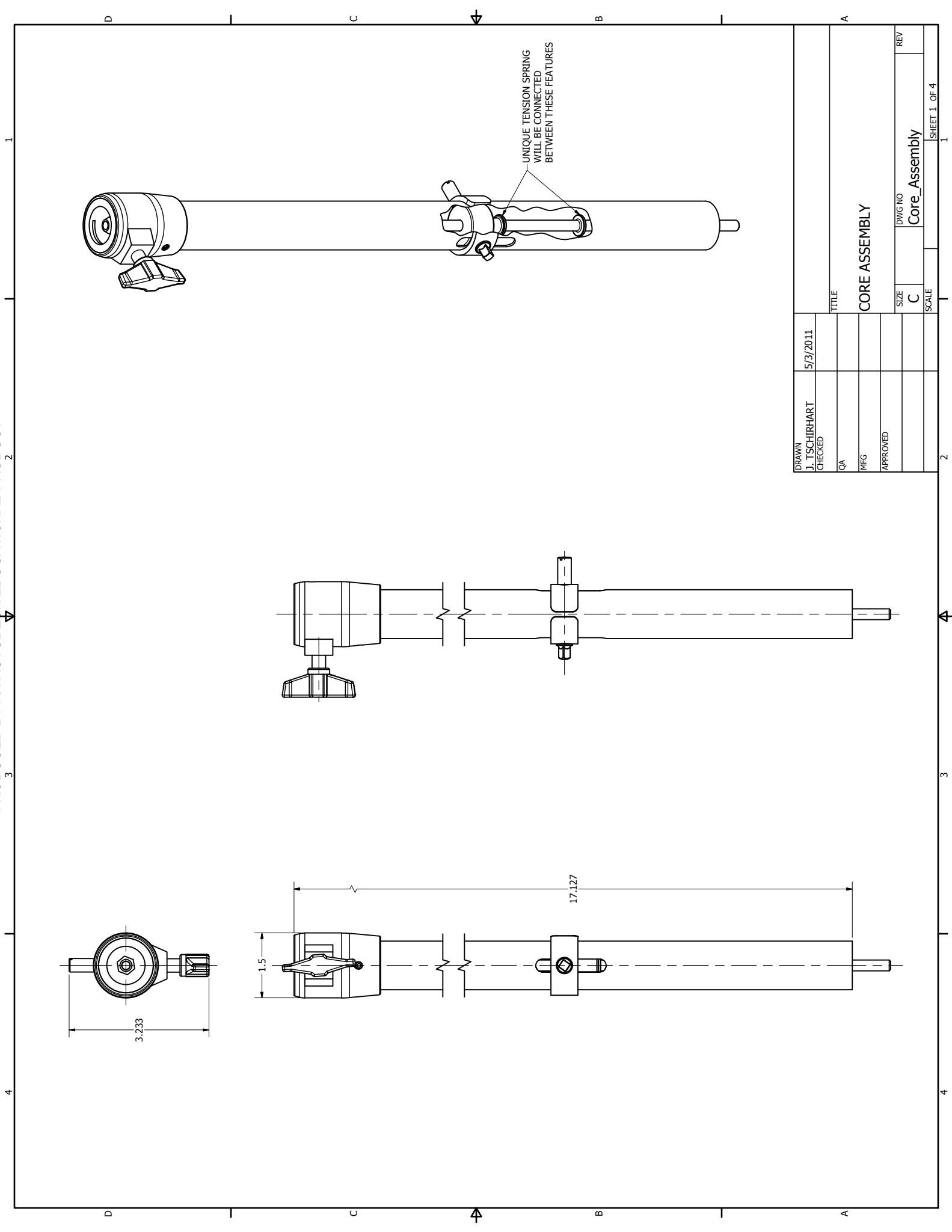

DRAWN J. TSCHIRHART	5/3/2011	TITLE	
CHECKED		CORE ASSEMBLY	
QA		SIZE	DWG NO
MFG		C	Core_Assembly
APPROVED		SCALE	REV
			1

PRODUCED BY AN AUTODESK EDUCATIONAL PRODUCT

PRODUCED BY AN AUTODESK EDUCATIONAL PRODUCT

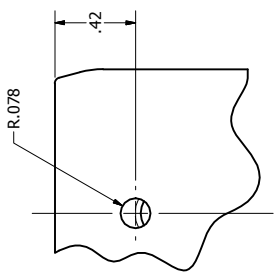
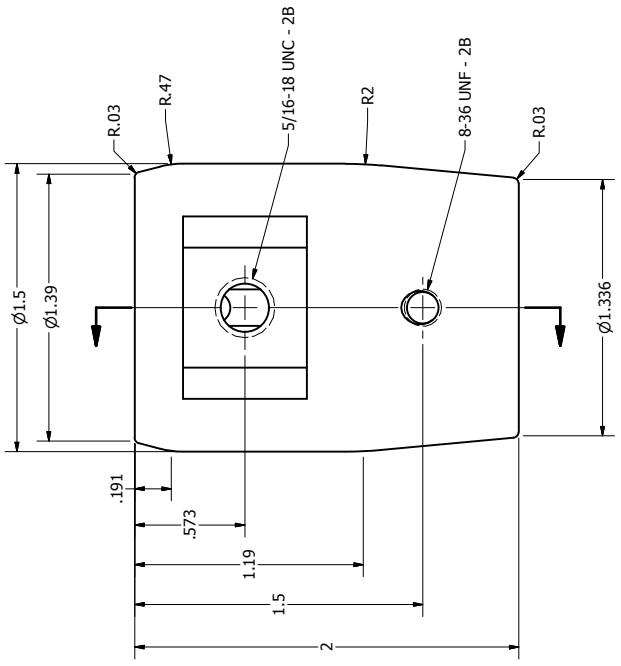
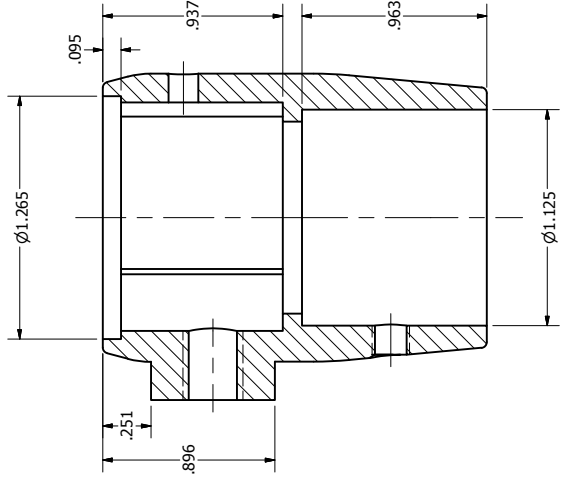
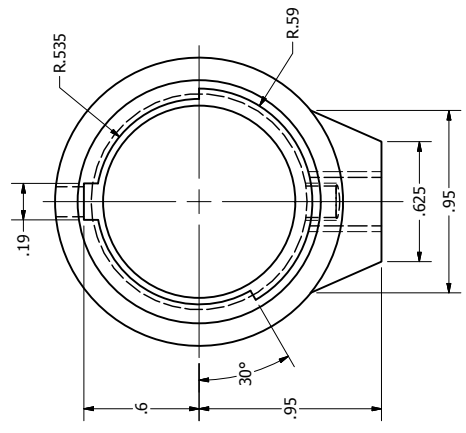
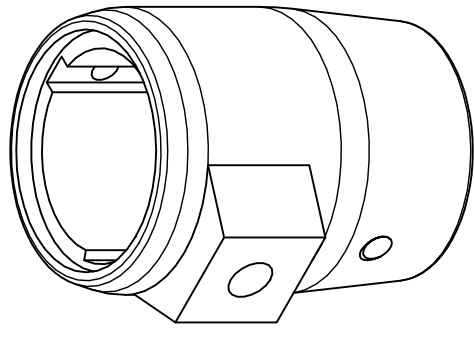

REAR VIEW DETAIL  
SCALE 2 : 1

COUPLING  
SCALE 2 : 1

DRAWN J. TSCHIRHART	5/3/2011	TITLE
CHECKED		CORE ASSEMBLY
QA		
MFG		
APPROVED		
SIZE	C	DWG NO Core_Assembly
REV		SCALE





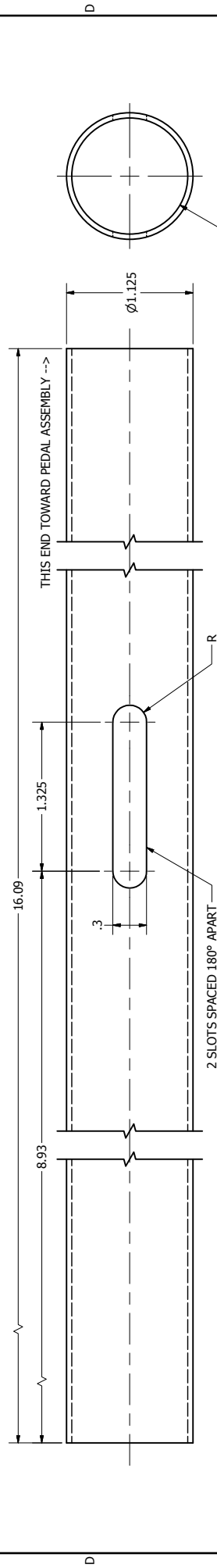

CORE TUBE  
SCALE 1.5:1

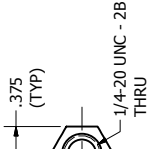

ROD COUPLER  
SCALE 1.5:1

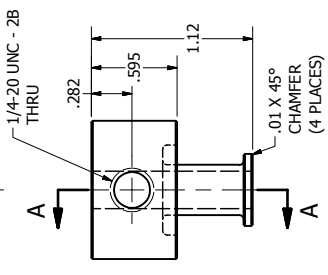
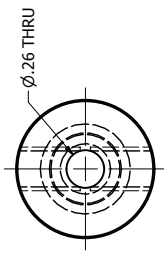

SECTION A-A  
TENSION CORE  
SCALE 1.5:1

CENTER ROD, LOWER HALF  
SCALE 1.5:1

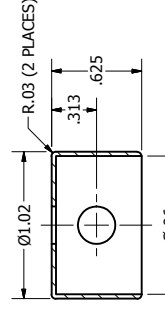
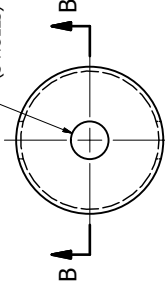
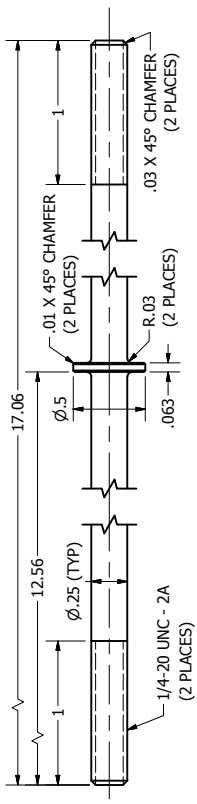

SECTION B-B  
TENSION SHELL  
SCALE 1.5:1

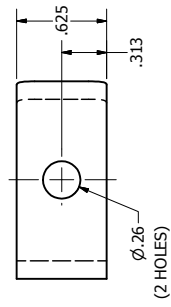
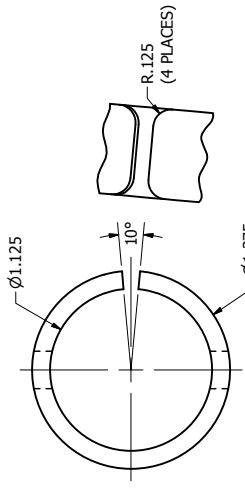

TENSION OUTER RING  
SCALE 1.5:1

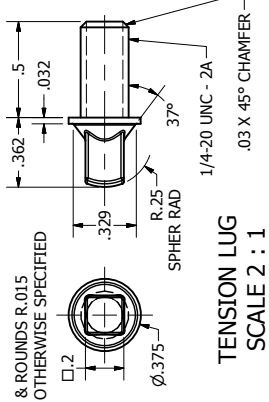

TENSION LUG  
SCALE 2:1

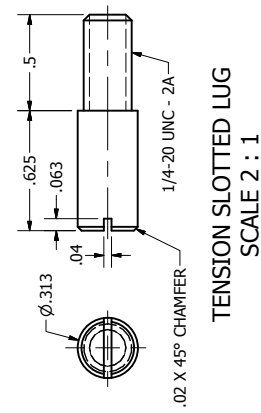

TENSION SLOTTED LUG  
SCALE 2:1

DRAWN J. TSCHIRHART	5/3/2011	TITLE
CHECKED		CORE ASSEMBLY
QA		
MFG		
APPROVED		
SIZE C	SCALE	REV
DWG NO Core_Assembly		
SHEET 4 OF 4		

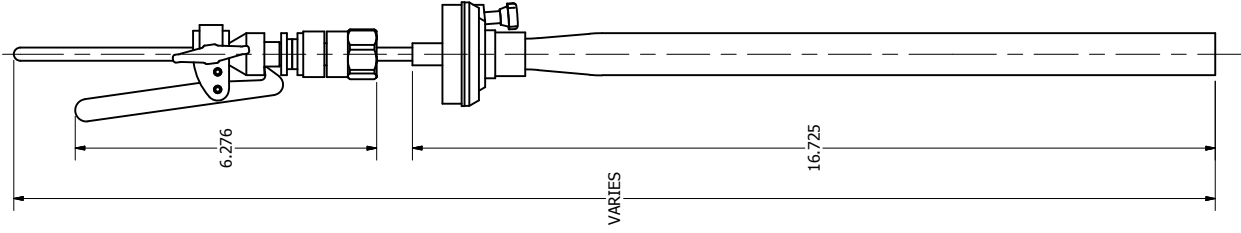
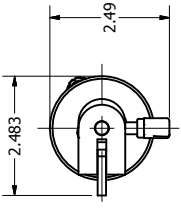

CYMBAL SEAT & CLUTCH ASSEMBLY  
SCALE 1 / 2

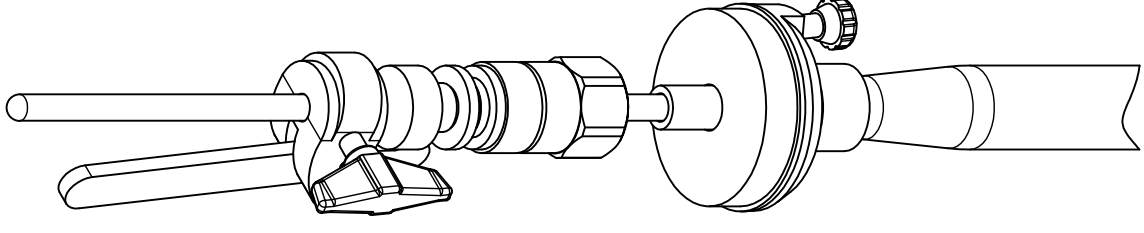

ISOMETRIC VIEW SHOWN AT FULL SCALE

DRAWN J. TSCHIRHART	5/6/2011	TITLE
CHECKED		
QA		
MFG		
APPROVED		
	SIZE C	REV Cymbal_Seat_and_Clutch_Assy
	SCALE	SHEET 1 OF 4

CYMBAL SEAT & CLUTCH ASSEMBLY

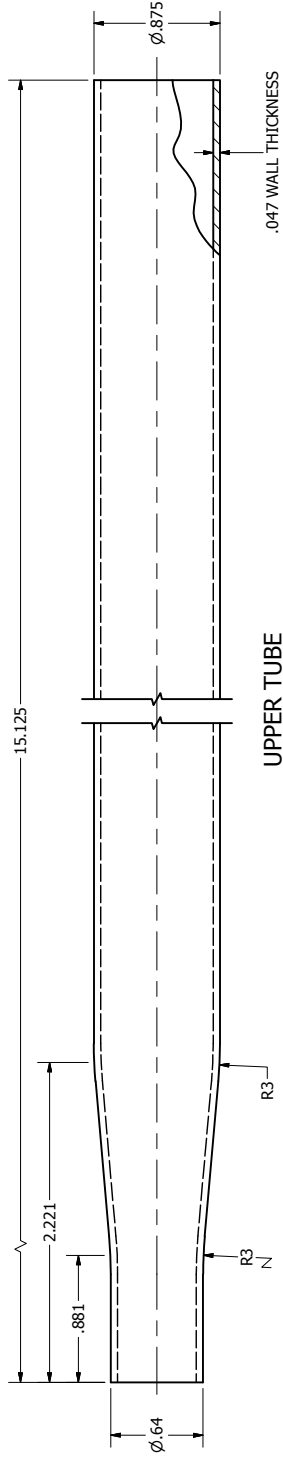

UPPER TUBE  
SCALE 1.5:1

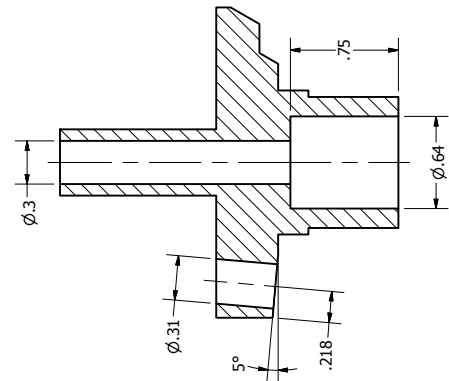

SECTION A-A

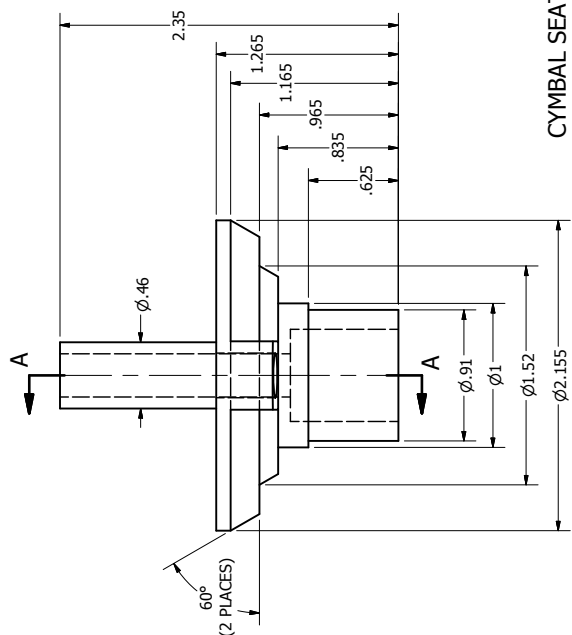

CYMBAL SEAT  
SCALE 1.5:1

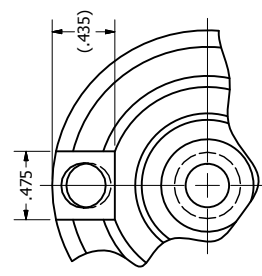

SEAT BOTTOM DETAIL

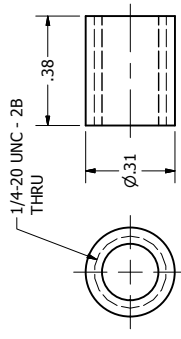

TILTER INSERT  
SCALE 3:1

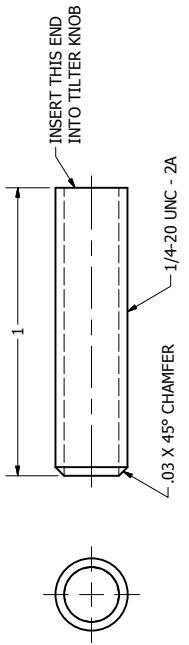

TILTER  
SCALE 3:1

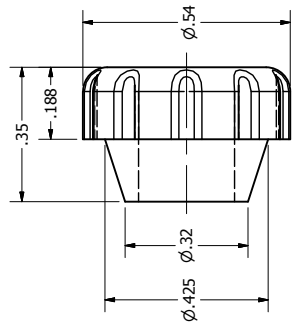

TILTER KNOB  
SCALE 4:1

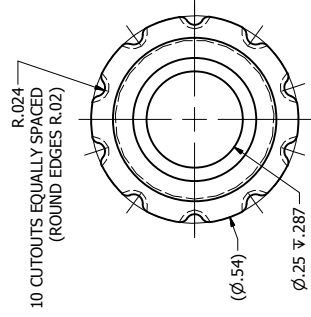

DRAWN	J. TSCHIRHART	5/6/2011	TITLE	
CHECKED				
QA				
MFG				
APPROVED				
SIZE	C	SCALE		
DWG NO	Cymbal_Seat_and_Clutch_Assy			REV

CYMBAL SEAT & CLUTCH ASSEMBLY

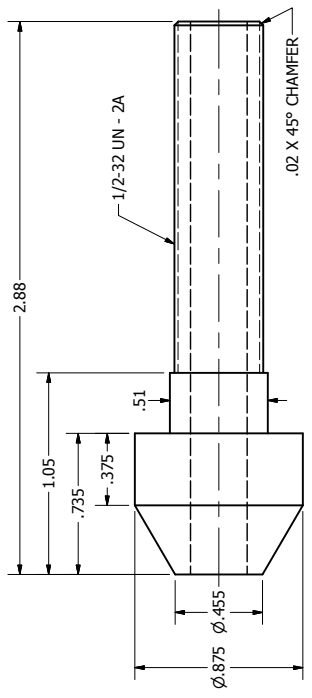

**MAIN CLUTCH BODY**  
SCALE 2 : 1

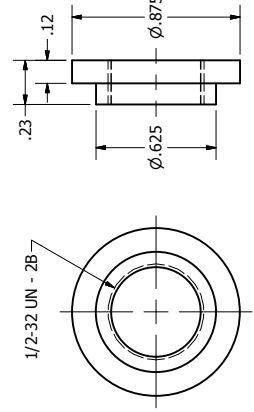

**THUMB NUT**  
SCALE 2 : 1

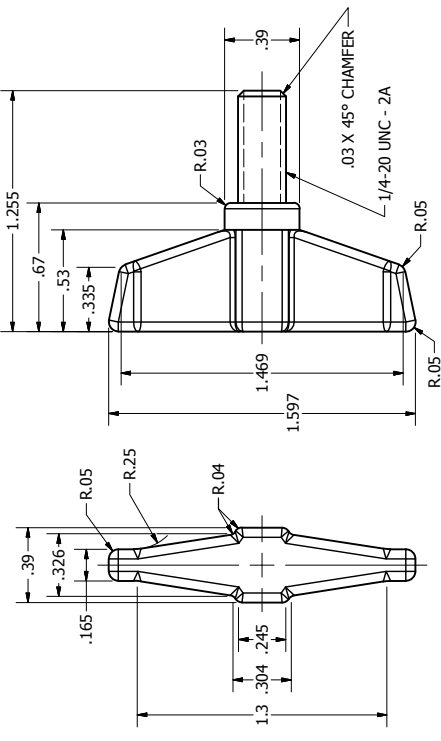

**CLUTCH WINGNUT**  
SCALE 2 : 1

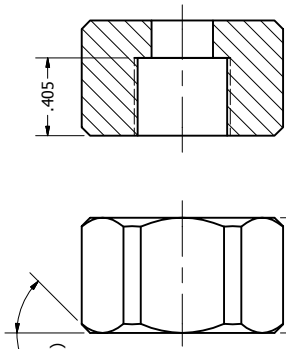

**CLUTCH NUT**  
SCALE 2 : 1

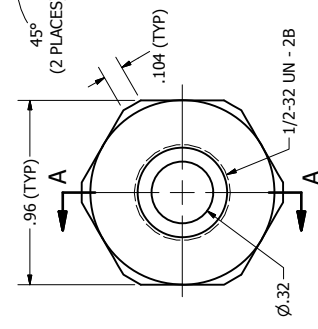

**SECTION A-A**

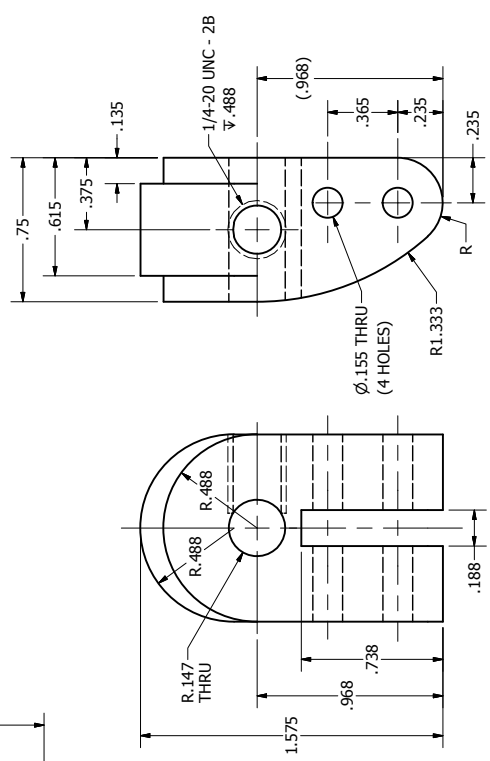

**DROP CLUTCH BODY**  
SCALE 2 : 1

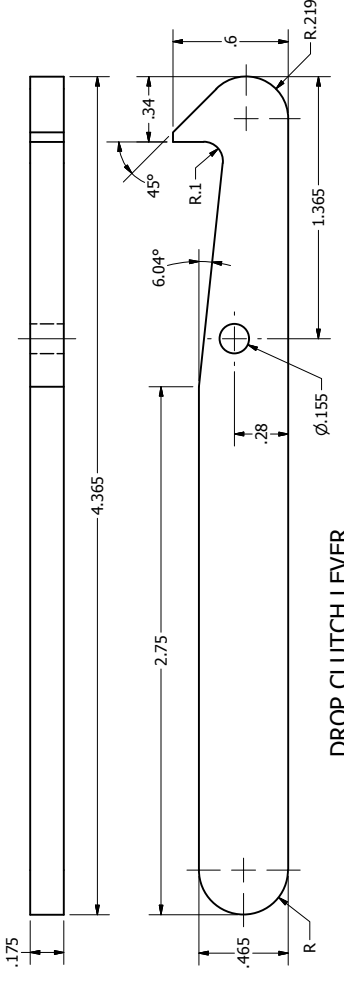

**DROP CLUTCH LEVER**  
SCALE 2 : 1

DRAWN J. TSCHIRHART	5/6/2011	TITLE
CHECKED		
QA		
MFG		
APPROVED		
<b>CYMBAL SEAT &amp; CLUTCH ASSEMBLY</b>		
SIZE C	DWG NO Cymbal_Seat_and_Clutch_Assy	REV
SCALE		SHEET 3 OF 4

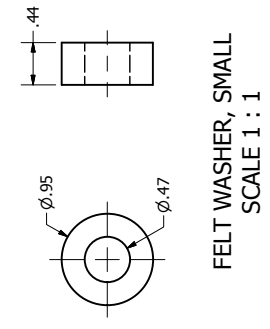

FELT WASHER, SMALL  
SCALE 1 : 1

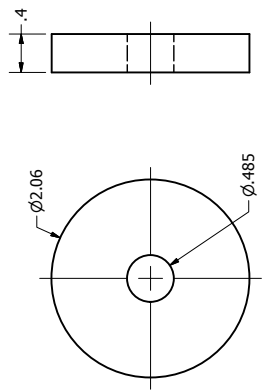

FELT WASHER, LARGE  
SCALE 1 : 1

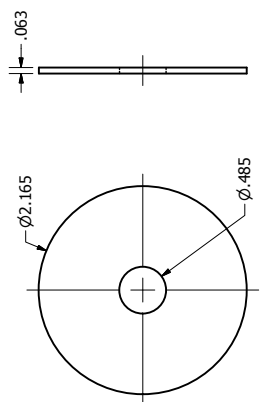

FENDER WASHER  
SCALE 1 : 1

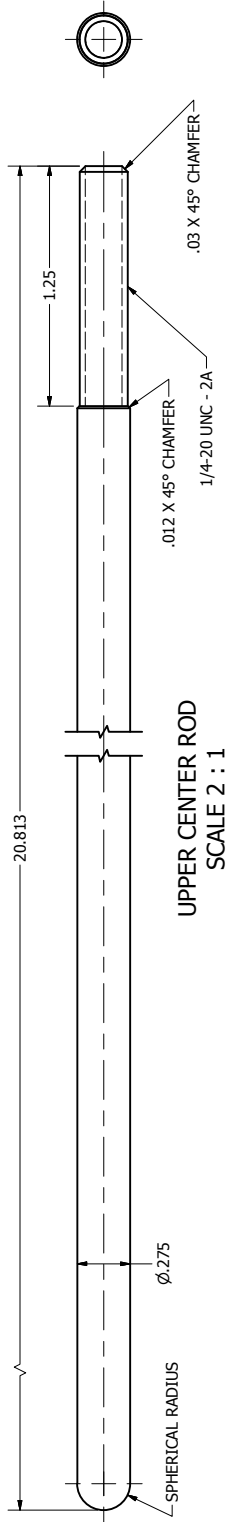

UPPER CENTER ROD  
SCALE 2 : 1

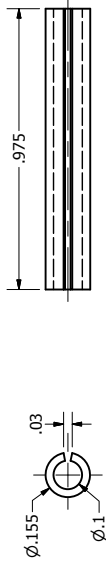

SPRING PIN, DROP CLUTCH  
SCALE 3 : 1

DRAWN	J. TSCHIRHART	5/6/2011	TITLE
CHECKED	QA		CYMBAL SEAT & CLUTCH ASSEMBLY
APPROVED	MFG		
REV	SIZE	DWG NO	REV
	C	Cymbal_Seat_and_Clutch_Assy	
	SCALE		SHEET 4 OF 4