

PVC SPIDER CUTAWAY VIEWS

NOTE: WING NUTS FOR FASTENING BOTTOM PLATE TO SPIDER BODY ARE NOT SHOWN

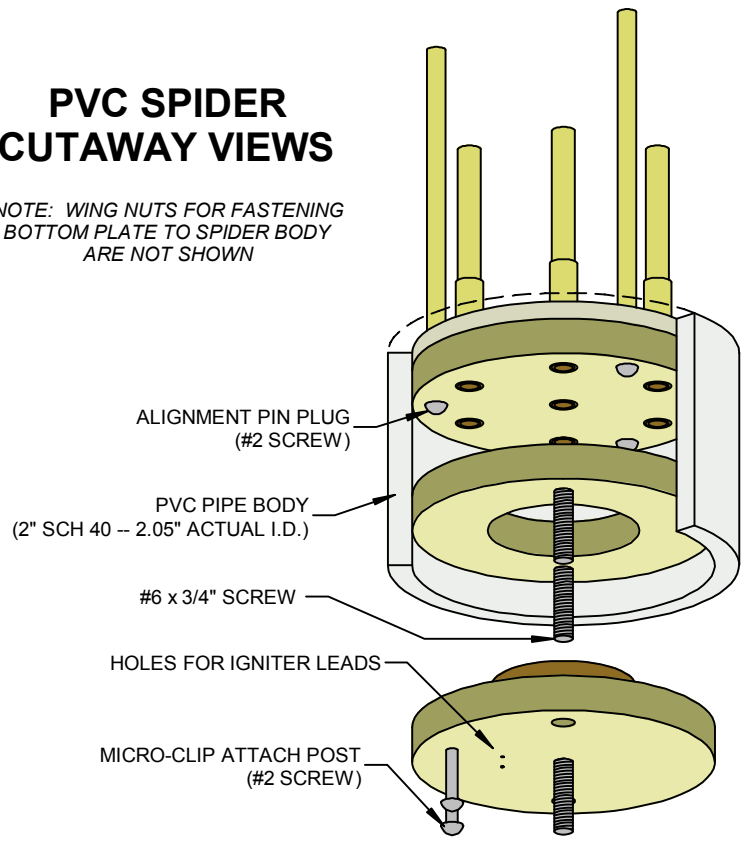

TO LAUNCH RAIL OR ROD →

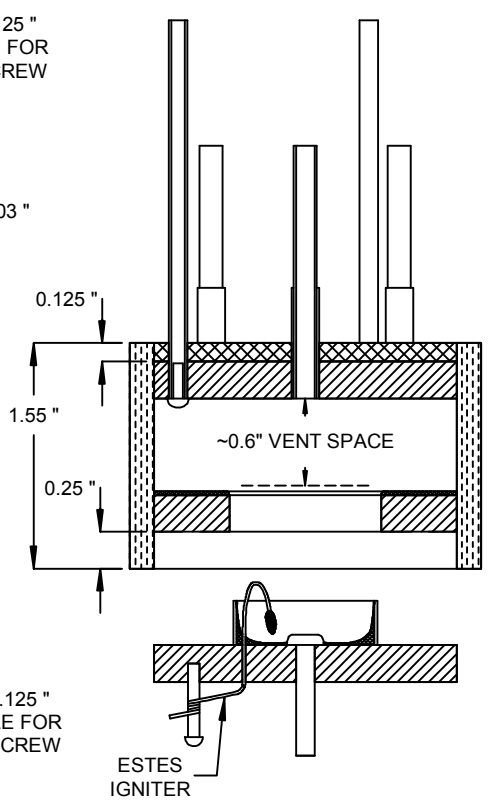
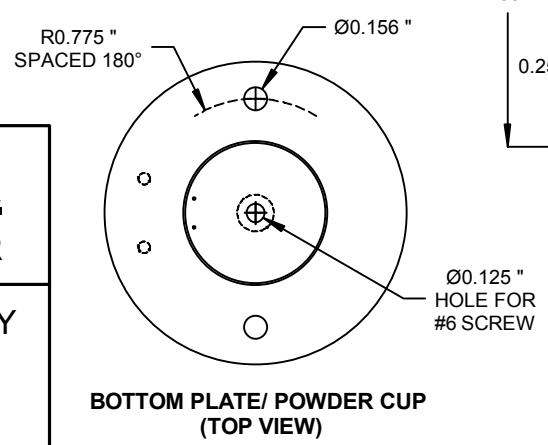
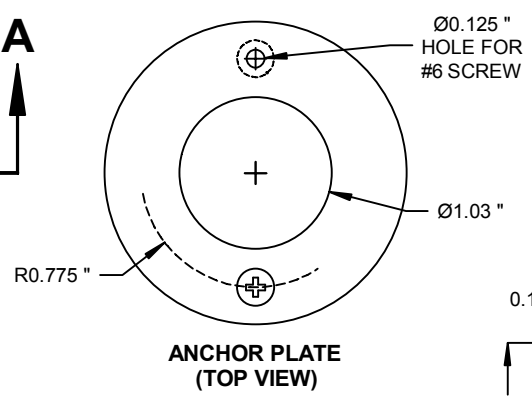
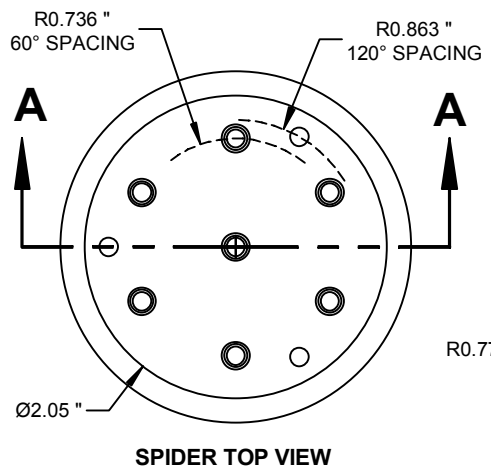

PVC SPIDER
FOR 7 X 18 MM CLUSTER
 DESIGNED AND DRAWN BY
 JOSHUA T. TSCHIRHART
 NAR 48098
 12 MARCH 2006